

Key: 5913

Town of BREWSTER - Fiscal Year 2025

9/17/2024 2:15 pm SEQ #: 6.141

LEG  
AL  
LAND

CURRENT OWNER		PARCEL ID		LOCATION	
FRANCIS CHRISTINE Q 30 FOX CROSSING ROAD BREWSTER, MA 02631		64-13-0		30 FOX CROSSING ROAD	
TRANSFER HISTORY		DOS	T	SALE PRICE	BK-PG (Cert)
FRANCIS CHRISTINE Q		11/05/2019	DC		(143224)
FRANCIS CHARLES D & CHRIS		01/03/1997	QS	55,000	(143224)
SUSAN & PETER KLEIN TRUST		04/06/1992	A	100	N/A-N/A

CLASS	CLASS%	DESCRIPTION		BN ID	BN	CARD	
1010	100	SINGLE FAMILY			1	1 of 1	
PMT NO	PMT DT	TY	DESC	AMOUNT	INSP	BY	1st %
599	09/06/2006	3	OUT BUILDING	4,000	08/11/2007	RJM	100 100
16	01/16/2004	2	ADD	4,000	06/01/2005	JB	100 100
99	03/06/2003	10	INGROUND POO	18,000	06/01/2005	JB	100 100
285	05/23/2000	2	ADD	190,000	06/01/2005	JB	100 100

CD	T	AC/SF/UN	Nbhd	St Ind	Infl	ADJ BASE	SAF	Topo	Lpi	VC	CREDIT AMT	ADJ VALUE				
100	S	60,000	12	1.00	12H	1.00	A	1.00	252,080	1.00	A	1.00	R06	1.15		348,850
300	A	0.001	12	1.00	12H	1.00	A	1.00	13,800	1.00	A	1.00	R06	1.15		10

TOTAL	1.378 Acres		ZONING	RM	FRNT	0	ASSESSED	CURRENT	PREVIOUS
Nbhd	NBHD 12		N O T E				LAND	348,900	329,100
St Ind	POSSUM WOODS						BUILDING	907,300	856,700
Infl	AVERAGE						DETACHED	20,600	20,300
							OTHER	0	0
							<b>TOTAL</b>	<b>1,276,800</b>	<b>1,206,100</b>

TY	QUAL	COND	DIM/NOTE	YB	UNITS	ADJ PRICE	RCNLD
SHF	A	1.00	20 0.80 14X16	2006	224	19.84	3,600
IPV	A	1.00	15 0.85 16X36	2003	576	34.72	17,000

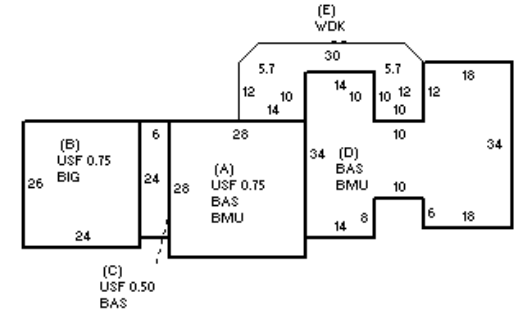

BLDG COMMENTS
PULL DOWN STAIRS TO ATTIC

DET  
ACHED

B  
U  
I  
L  
D  
I  
N  
G

BUILDING	CD	ADJ	DESC	MEASURE	4/11/2019	NF
MODEL	1		RESIDENTIAL	LIST	4/11/2019	NF
STYLE	4	1.02	CAPE [100%]	REVIEW	12/30/2019	MR
QUALITY	A+	1.20	AVG + [100%]			
FRAME	1	1.00	WD FRAME [100%]			

YEAR BLT	1997	SIZE ADJ	0.980	ELEMENT	CD	DESCRIPTION	ADJ	S	BAT	T	DESCRIPTION	UNITS	YB	ADJ PRICE	RCN
NET AREA	3,304	DETAIL ADJ	1.000	FOUNDATION	4	FLR & WALL	1.00	+	BMU	N	BSMT UNFINISHED	2,032		57.18	116,198
\$NLA(RCN)	\$312	OVERALL	1.020	EXT COVER	1	WD SHINGLE	1.00	+	BAS	L	BASE AREA	2,032	1997	266.11	540,742
				ROOF SHAPE	1	GABLE	1.00	+	USF	L	UPPER STORY FIN	1,056	1997	211.53	223,373
				ROOF COVER	1	ASPH/CMP SH	1.00	B	BIG	N	BUILT-IN GARAGE	624		57.05	35,597
				FLOOR COVER	1	HARDWOOD	1.00	C	BAS	L	BASE AREA	144	2000	266.11	38,320
				INT FINISH	2	DRYWALL	1.00	C	USF	L	UPPER STORY FIN	72	2000	211.53	15,230
				HEATING/COOL	2	HOT WATER	1.00	E	WDK	N	WOOD DECK	452		47.02	21,253
				FUEL SOURCE	2	GAS	1.00	F21	O		FPL 2S 10P	1		12,176.30	12,176
								ODS	O		OUTDOOR SHOWER	1		2,896.80	2,897
								WPL	O		WHIRLPOOL	1		9,277.10	9,277

TOTAL RCN	1,030,976	
CONDITION ELEM	CD	
EXTERIOR	G	
INTERIOR	A	
KITCHEN	G	
BATHS	G	
HEAT/ELEC	A	
EFF.YR/AGE	2009 / 14	
COND	12	12 %
FUNC	0	
ECON	0	
DEPR	12	% GD 88
RCNLD	\$907,300	