

Key: 6047

Town of BREWSTER - Fiscal Year 2025

9/17/2024 2:15 pm SEQ #: 6.274

LEGALS

| CURRENT OWNER | | PARCEL ID | | LOCATION | |
|---|--|------------|----|-------------------|--------------|
| TURNER GAIL TRUSTEE THE GAIL TURNER 2016 LIVING TRUST 320 RUN HILL ROAD BREWSTER, MA 02631 | | 45-4-0 | | 320 RUN HILL ROAD | |
| TRANSFER HISTORY | | DOS | T | SALE PRICE | BK-PG (Cert) |
| TURNER GAIL TRUSTEE | | 11/09/2016 | A | 1 (211260) | |
| SPIER PETER L & | | 09/21/1982 | XX | (89681) | |

| CLASS | CLASS% | DESCRIPTION | | BN ID | BN | CARD | |
|--------|------------|---------------|-------------|--------|------------|--------|---------|
| 1010 | 100 | SINGLE FAMILY | | | 1 | 1 of 1 | |
| PMT NO | PMT DT | TY | DESC | AMOUNT | INSP | BY | 1st % |
| 113 | 02/10/2014 | 5 | OTHER | 15,755 | 05/28/2015 | MW | 100 100 |
| 1263 | 03/02/2007 | 7 | ALTERATIONS | 9,000 | 01/24/2008 | JH | 100 100 |
| 103 | 03/03/2000 | 5 | OTHER | 800 | | | 100 100 |
| 581 | 10/07/1999 | 2 | ADD | 3,200 | 03/25/2000 | LB | 100 100 |
| 382 | 07/14/1998 | 2 | ADD | 8,000 | | | 100 100 |

LAND

| CD | T | AC/SF/UN | Nbhd | St Ind | Infl | ADJ BASE | SAF | Topo | Lpi | VC | CREDIT AMT | ADJ VALUE | | | | |
|-----|---|----------|------|--------|------|----------|-----|------|---------|------|------------|-----------|-----|------|--|---------|
| 100 | S | 60,000 | 12 | 1.00 | 12N | 1.00 | A | 1.00 | 186,320 | 1.00 | 50 | 0.50 | PF3 | 1.70 | | 257,850 |
| 300 | A | 0.003 | 12 | 1.00 | 12N | 1.00 | A | 1.00 | 20,400 | 1.00 | A | 1.00 | PF3 | 1.70 | | 60 |

| | | | | | | | | |
|--------|-------------|--|----------|-----------|---------|----------|---------|----------|
| TOTAL | 1.380 Acres | ZONING | RR | FRNT | 0 | ASSESSED | CURRENT | PREVIOUS |
| Nbhd | NBHD 12 | NOTE TOPO=MINIMAL POND FRONT/ACCESS TO POND | LAND | 257,900 | 243,300 | | | |
| St Ind | MILL POND | | BUILDING | 781,300 | 746,700 | | | |
| Infl | AVERAGE | | DETACHED | 6,400 | 6,400 | | | |
| | | | OTHER | 0 | 0 | | | |
| | | | TOTAL | 1,045,600 | 996,400 | | | |

DETACHED

| TY | QUAL | COND | DIM/NOTE | YB | UNITS | ADJ PRICE | RCNLD | |
|-----|------|------|----------|-------|-------|-----------|-------|-------|
| SHF | G | 1.20 | 10 0.90 | 12X16 | 2000 | 192 | 24.92 | 4,300 |
| SHF | A | 1.00 | 30 0.70 | 10X14 | | 140 | 21.39 | 2,100 |

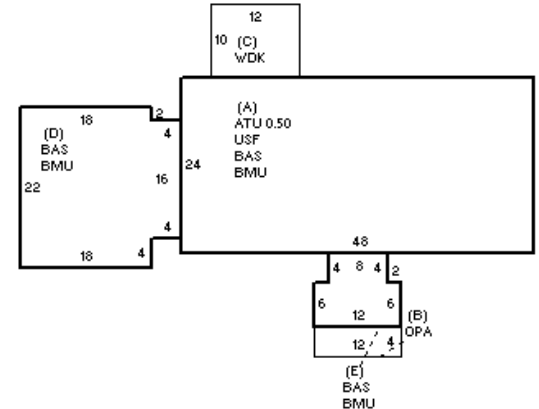

BUILDING

| BUILDING | CD | ADJ | DESC | MEASURE | 3/27/2018 | NF |
|----------|----|------|------------------|---------|------------|----|
| MODEL | 1 | | RESIDENTIAL | LIST | 4/10/2018 | NF |
| STYLE | 8 | 0.95 | CONTEMPOR [100%] | REVIEW | 11/21/2018 | TD |
| QUALITY | G | 1.30 | GOOD [100%] | | | |
| FRAME | 1 | 1.00 | WD FRAME [100%] | | | |

BLDG COMMENTS
GENERATOR
STAIRWAY TO ATTIC

| YEAR BLT | 1990 | SIZE ADJ | 0.990 | ELEMENT | CD | DESCRIPTION | ADJ | S | BAT | T | DESCRIPTION | UNITS | YB | ADJ PRICE | RCN | TOTAL RCN | 952,782 |
|------------|-------|------------|-------|--------------|----|-------------|------|---|-----|---|-----------------|-------|------|-----------|---------|----------------|------------|
| NET AREA | 2,868 | DETAIL ADJ | 1.000 | FOUNDATION | 4 | FLR & WALL | 1.00 | + | BMU | N | BSMT UNFINISHED | 1,716 | | 64.52 | 110,712 | | |
| \$NLA(RCN) | \$332 | OVERALL | 0.980 | EXT COVER | 10 | VERT BOARD | 0.98 | + | BAS | L | BASE AREA | 1,716 | 1990 | 298.46 | 512,165 | | |
| | | | | ROOF SHAPE | 1 | GABLE | 1.00 | A | USF | L | UPPER STORY FIN | 1,152 | 1990 | 222.42 | 256,222 | | |
| | | | | ROOF COVER | 1 | ASPH/CMP SH | 1.00 | A | ATU | N | ATTIC UNF | 576 | | 67.35 | 38,794 | | |
| | | | | FLOOR COVER | 1 | HARDWOOD | 1.00 | B | OPA | N | OPEN PORCH | 48 | | 63.06 | 3,027 | | |
| | | | | INT FINISH | 2 | DRYWALL | 1.00 | C | WDK | N | WOOD DECK | 120 | | 49.44 | 5,933 | | |
| | | | | HEATING/COOL | 11 | HTWT/CL AIR | 1.05 | | MST | O | MAS/METAL STACK | 2 | | 6,339.70 | 12,679 | | |
| | | | | FUEL SOURCE | 2 | GAS | 1.00 | | | | | | | | | | |
| | | | | | | | | | | | | | | | | CONDITION ELEM | CD |
| | | | | | | | | | | | | | | | | EXTERIOR | G |
| | | | | | | | | | | | | | | | | INTERIOR | A |
| | | | | | | | | | | | | | | | | KITCHEN | A |
| | | | | | | | | | | | | | | | | BATHS | A |
| | | | | | | | | | | | | | | | | HEAT/ELEC | G |
| | | | | | | | | | | | | | | | | EFF.YR/AGE | 1997 / 26 |
| | | | | | | | | | | | | | | | | COND | 18 18 % |
| | | | | | | | | | | | | | | | | FUNC | 0 |
| | | | | | | | | | | | | | | | | ECON | 0 |
| | | | | | | | | | | | | | | | | DEPR | 18 % GD 82 |
| | | | | | | | | | | | | | | | | RCNLD | \$781,300 |