

Key: 6053

Town of BREWSTER - Fiscal Year 2025

9/17/2024 2:15 pm SEQ #: 6.280

LEGALS

CURRENT OWNER		PARCEL ID		LOCATION								
SILVER JOEL S & SUSAN C 62 COVENTRY LANE AVON, CT 06001		45-1-0		366 RUN HILL ROAD								
TRANSFER HISTORY		DOS	T	SALE PRICE	BK-PG (Cert)							
SILVER JOEL S & SUSAN C		10/03/2008	A	1 23192-252								
SILVER JACQUELINE &		12/22/2003	J	1 18055-111								
SILVER JACQUELINE &		05/01/2002	J	1 15115-153								
CD	T	AC/SF/UN	Nbhd	St Ind	Infl	ADJ BASE	SAF	Topo	Lpi	VC	CREDIT AMT	ADJ VALUE
100	S	60,000	12	1.00	12N	1.00	A	1.00				515,690
300	A	1,393	12	1.00	12N	1.00	A	1.00	PF3	1.70		28,420

DETACHED

TOTAL	2.770 Acres	ZONING	RR	FRNT	0	ASSESSED	CURRENT	PREVIOUS
Nbhd	NBHD 12	NOTE				LAND	544,100	513,300
St Ind	MILL POND		LAND	1,226,000	1,124,900			
Infl	AVERAGE		DETACHED	2,100	2,100			
			OTHER	502,700	473,700			
TOTAL						2,274,900	2,114,000	

TY	QUAL	COND	DIM/NOTE	YB	UNITS	ADJ PRICE	RCNLD
SHF	A	1.00	30 0.70 10X14	2001	140	21.39	2,100



BLDG COMMENTS
 BMF= FAM RM, BATH (PER OWNER 7/2/24)
 3 EXTRA FIX

BUILDING

BUILDING	CD	ADJ	DESC	MEASURE	3/16/2012	MR
MODEL	1		RESIDENTIAL	LIST	3/16/2012	MR
STYLE	5	1.05	COLONIAL [100%]	REVIEW	7/25/2024	EMZ
QUALITY	V	1.65	VERY GOOD [100%]			
FRAME	1	1.00	WD FRAME [100%]			

CLASS	CLASS%	DESCRIPTION		BN ID	BN	CARD	
1010	100	SINGLE FAMILY			1	1 of 2	
PMT NO	PMT DT	TY	DESC	AMOUNT	INSP	BY	1st %
23-548	06/07/2023	7	ALTERATIONS	60,000	07/02/2024	TCK	100 100
329	04/27/2017	7	ALTERATIONS	22,000	06/07/2018	NF	100 100
936	12/05/2012	7	ALTERATIONS	11,000	01/30/2013	MR	100 100
269	04/20/2012	1	NEW CONSTRUC	310,000	08/12/2014	RJM	100 100
247	04/11/2012	6	DEMO	5,000	01/30/2013	MR	100 100

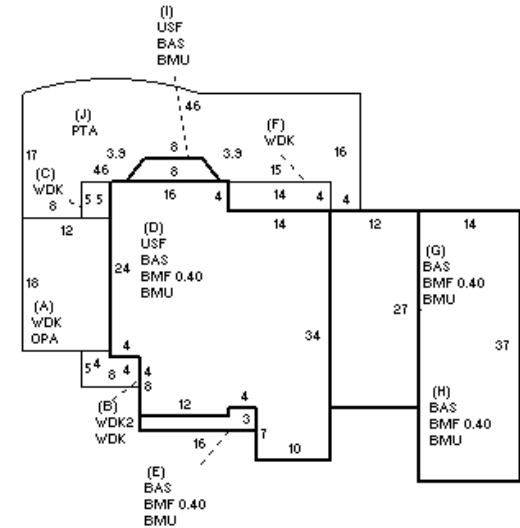

G

YEAR BLT	2011	SIZE ADJ	0.990	ELEMENT	CD	DESCRIPTION	ADJ	S	BAT	T	DESCRIPTION	UNITS	YB	ADJ PRICE	RCN	TOTAL RCN	1,377,578
NET AREA	2,798	DETAIL ADJ	1.000	FOUNDATION	4	FLR & WALL	1.00	A	OPA	N	OPEN PORCH	216		88.21	19,053		
\$NLA(RCN)	\$492	OVERALL	1.080	EXT COVER	1	WD SHINGLE	1.00	+	WDK	N	WOOD DECK	364		69.16	25,173		
				ROOF SHAPE	1	GABLE	1.00	+	BMU	N	BSMT UNFINISHED	1,838		87.95	161,657		
				ROOF COVER	1	ASPH/CMP SH	1.00	+	BMF	N	BSMT FINISH	722		66.32	47,885		
				FLOOR COVER	1	HARDWOOD	1.00	+	BAS	L	BASE AREA	1,514	2011	408.78	618,890		
				INT FINISH	2	DRYWALL	1.00	+	USF	L	UPPER STORY FIN	960	2011	321.03	308,190		
				HEATING/COOL	9	WARM/CL AIR	1.03	G	BAS	L	BASE AREA	324	2011	408.78	132,444		
				FUEL SOURCE	2	GAS	1.00	J	PTA	N	PATIO	609		21.04	12,812		
									GFP	O	GAS FIREPLACE	1		5,514.80	5,515		
									ODS	O	OUTDOOR SHOWER	1		4,260.50	4,261		
																TOTAL RCN	1,377,578
																CONDITION ELEM	CD
																EXTERIOR	A
																INTERIOR	A
																KITCHEN	A
																BATHS	A
																HEAT/ELEC	A
																EFF.YR/AGE	2011 / 12
																COND	11 11 %
																FUNC	0
																ECON	0
																DEPR	11 % GD 89
																RCNLD	\$1,226,000

Key: 6053

Town of BREWSTER - Fiscal Year 2025

9/17/2024 2:15 pm SEQ #: 6.281

LEGAL

CURRENT OWNER				PARCEL ID				LOCATION			
SILVER JOEL S & SUSAN C 62 COVENTRY LANE AVON, CT 06001				45-1-0				366 RUN HILL ROAD			
TRANSFER HISTORY				DOS	T	SALE PRICE	BK-PG (Cert)				

CLASS	CLASS%	DESCRIPTION			BN ID	BN	CARD	
1010	100	SINGLE FAMILY				2	2 of 2	
PMT NO	PMT DT	TY	DESC	AMOUNT	INSP	BY	1st	%

LAND

CD	T	AC/SF/UN	Nbhd	St Ind	Infl	ADJ BASE	SAF	Topo	Lpi	VC	CREDIT AMT	ADJ VALUE

TOTAL	ZONING	FRNT	ASSESSED	CURRENT	PREVIOUS
Nbhd	NOTE		LAND BUILDING DETACHED OTHER TOTAL	502,700	
St Ind					
Infl					

DETACHED

TY	QUAL	COND	DIM/NOTE	YB	UNITS	ADJ PRICE	RCNLD

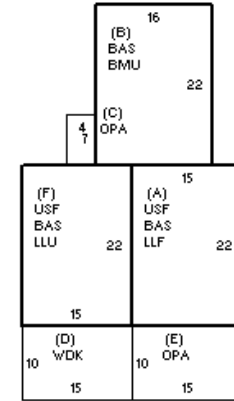

BUILDING

BUILDING	CD	ADJ	DESC	MEASURE	1/30/2013	MR
MODEL	1		RESIDENTIAL	LIST	1/30/2013	EST
STYLE	5	1.05	COLONIAL [100%]	REVIEW	7/25/2024	EMZ
QUALITY	A	1.00	AVG [100%]			
FRAME	1	1.00	WD FRAME [100%]			

BLDG COMMENTS
INTERIOR ESTIMATED PER PLANS

G

YEAR BLT	2012	SIZE ADJ	1.000	ELEMENT	CD	DESCRIPTION	ADJ	S	BAT	T	DESCRIPTION	UNITS	YB	ADJ PRICE	RCN	TOTAL RCN	552,388				
NET AREA	2,002	DETAIL ADJ	1.000	FOUNDATION	4	FLR & WALL	1.00	A	LLF	L	LOWER LEVEL FIN	330	2017	152.80	50,423	CONDITION ELEM	CD				
\$NLA(RCN)	\$276	OVERALL	1.080	EXT COVER	1	WD SHINGLE	1.00	+	BAS	L	BASE AREA	1,012	2012	282.19	285,579	EXTERIOR	A				
				ROOF SHAPE	1	GABLE	1.00	+	USF	L	UPPER STORY FIN	660	2012	198.56	131,047	INTERIOR	A				
				ROOF COVER	1	ASPH/CMP SH	1.00	B	BMU	N	BSMT UNFINISHED	352		72.19	25,412	KITCHEN	A				
				FLOOR COVER	1	HARDWOOD	1.00	+	OPA	N	OPEN PORCH	178		54.00	9,612	BATHS	A				
				INT FINISH	2	DRYWALL	1.00	D	WDK	N	WOOD DECK	150		42.34	6,350	HEAT/ELEC	A				
				HEATING/COOL	9	WARM/CL AIR	1.03	F	LLU	N	LOWER LEVEL UNF	330		99.79	32,931						
				FUEL SOURCE	2	GAS	1.00		ODS	O	OUTDOOR SHOWER	1		2,608.20	2,608						
																		EFF.YR/AGE	2013 / 10		
																		COND	10 10 %		
																		FUNC	0		
																		ECON	0		
																		DEPR	9	% GD	91
																		RCNLD	\$502,700		