

Key: 6093

Town of BREWSTER - Fiscal Year 2025

9/17/2024 2:15 pm SEQ #: 6.325

LEGALS

CURRENT OWNER				PARCEL ID				LOCATION			
WALTHER MICHAEL G & WENDY T 171 LELAND ROAD BREWSTER, MA 02631				34-30-0				171 LELAND ROAD			
TRANSFER HISTORY				DOS	T	SALE PRICE	BK-PG (Cert)				
WALTHER MICHAEL G & WENDY				06/04/1998	QS	44,000	(148807)				
MCDONOUGH ANDREW L & NANC				10/12/1984	XX		N/A-N/A				

CLASS	CLASS%	DESCRIPTION			BN ID	BN	CARD	
1010	100	SINGLE FAMILY				1	1 of 1	
PMT NO	PMT DT	TY	DESC	AMOUNT	INSP	BY	1st	%
744		14	CYCLICAL GRO		10/12/2017	NF	100	100
76	09/06/2013	7	ALTERATIONS	3,500	08/09/2014	RJM	100	100
66	02/27/2004	2	ADD	79,000	06/28/2004	WH	100	100
376	02/19/2004	3	OUT BUILDING	2,000	06/28/2004	WH	100	100
	06/19/2003	2	ADD	40,000	06/28/2004	WH	100	100

LAND

CD	T	AC/SF/UN	Nbhd	St Ind	Infl	ADJ BASE	SAF	Topo	Lpi	VC	CREDIT AMT	ADJ VALUE
100	S	21,600	12	1.00	12F 1.00	A 1.00	219,200	2.08	A 1.00	R03 1.00		226,180

TOTAL	21,606 SF	ZONING	RL	FRNT	0	ASSESSED	CURRENT	PREVIOUS
Nbhd	NBHD 12	NOTE	LAND	226,200	213,400			
St Ind	LELAND/CRANE		BUILDING	567,600	536,200			
Infl	AVERAGE		DETACHED	1,900	1,900			
			OTHER	0	0			
			TOTAL	795,700	751,500			

DETACHED

TY	QUAL	COND	DIM/NOTE	YB	UNITS	ADJ PRICE	RCNLD
SHF	A	1.00	10 0.90 8X12	2004	96	22.01	1,900

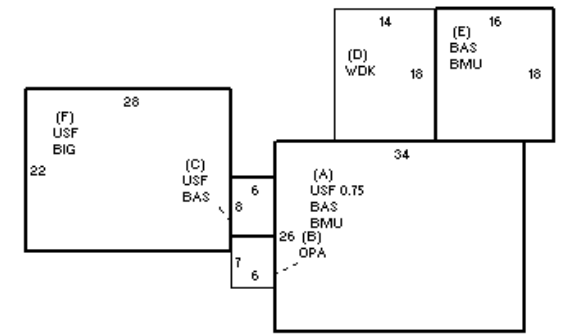

BUILDING	CD	ADJ	DESC	MEASURE	10/12/2017	NF
MODEL	1		RESIDENTIAL	LIST	10/12/2017	EST
STYLE	4	1.02	CAPE [100%]	REVIEW	11/15/2017	TD
QUALITY	A	1.00	AVG [100%]			
FRAME	1	1.00	WD FRAME [100%]			

BUILDING

YEAR BLT	1998	SIZE ADJ	0.990
NET AREA	2,547	DETAIL ADJ	1.000
\$NLA(RCN)	\$269	OVERALL	1.050
CAPACITY		UNITS	ADJ
STORIES	1.75	1.00	
ROOMS	8	1.00	
BEDROOMS	4	1.00	
BATHROOMS	3	1.00	
FIXTURES	10	\$13,650	
GARAGE SPACES	2	1.00	
% BSMT FIN	0	1.00	
# 1/2 BATHS	0	1.00	
# OF UNITS	1	1.00	

ELEMENT	CD	DESCRIPTION	ADJ
FOUNDATION	4	FLR & WALL	1.00
EXT COVER	1	WD SHINGLE	1.00
ROOF SHAPE	1	GABLE	1.00
ROOF COVER	1	ASPH/CMP SH	1.00
FLOOR COVER	1	HARDWOOD	1.00
INT FINISH	2	DRYWALL	1.00
HEATING/COOL	9	WARM/CL AIR	1.03
FUEL SOURCE	2	GAS	1.00

S	BAT	T	DESCRIPTION	UNITS	YB	ADJ PRICE	RCN
+	BMU	N	BSMT UNFINISHED	1,172		58.69	68,789
+	USF	L	UPPER STORY FIN	711	1998	175.51	124,787
B	OPA	N	OPEN PORCH	42		51.98	2,183
+	BAS	L	BASE AREA	1,220	1998	256.24	312,609
D	WDK	N	WOOD DECK	252		40.75	10,268
F	BIG	N	BUILT-IN GARAGE	616		49.44	30,453
F	USF	L	UPPER STORY FIN	616	2003	175.51	108,113
	F21	O	FPL 2S 1OP	1		10,552.00	10,552
	ODS	O	OUTDOOR SHOWER	1		2,510.40	2,510

TOTAL RCN	683,915
CONDITION ELEM	CD
EXTERIOR	A
INTERIOR	A
KITCHEN	A
BATHS	A
HEAT/ELEC	A
EFF. YR/AGE	1999 / 24
COND	17 17 %
FUNC	0
ECON	0
DEPR	17 % GD 83
RCNLD	\$567,600