

Key: 6212

Town of BREWSTER - Fiscal Year 2025

9/17/2024 2:15 pm SEQ #: 6.445

LEGALS

CURRENT OWNER		PARCEL ID		LOCATION	
CRAFT KINGSLEY W & DIANE C		13-79-0		184 POND VIEW DRIVE	
184 POND VIEW DRIVE		TRANSFER HISTORY		DOS	T
BREWSTER, MA 02631		CRAFT KINGSLEY W & DIANE		04/30/1993	QS
		SALE PRICE	BK-PG (Cert)		
		200,000	(129969)		

CLASS	CLASS%	DESCRIPTION			BN ID	BN	CARD	
1010	100	SINGLE FAMILY				1	1 of 1	
PMT NO	PMT DT	TY	DESC	AMOUNT	INSP	BY	1st	%
653	09/01/2015	7	ALTERATIONS	11,763	05/11/2016	WFF	100	100

LAND

CD	T	AC/SF/UN	Nbhd	St Ind	Infl	ADJ BASE	SAF	Topo	Lpi	VC	CREDIT AMT	ADJ VALUE				
100	S	60,000	12	1.00	A	1.00	A	1.00	230,160	1.00	A	1.00	PF1	1.05		318,510
300	A	0.003	12	1.00	A	1.00	A	1.00	12,600	1.00	A	1.00	PF1	1.05		40

TOTAL	1.380 Acres	ZONING	RL	FRNT	0	ASSESSED	CURRENT	PREVIOUS
Nbhd	NBHD 12	NOTE	POND VIEW			LAND	318,600	300,500
St Ind	AVERAGE		BUILDING	489,000	461,800			
Infl	AVERAGE		DETACHED	0	0			
			OTHER	0	0			
						TOTAL	807,600	762,300

DETACHED

TY	QUAL	COND	DIM/NOTE	YB	UNITS	ADJ PRICE	RCNLD

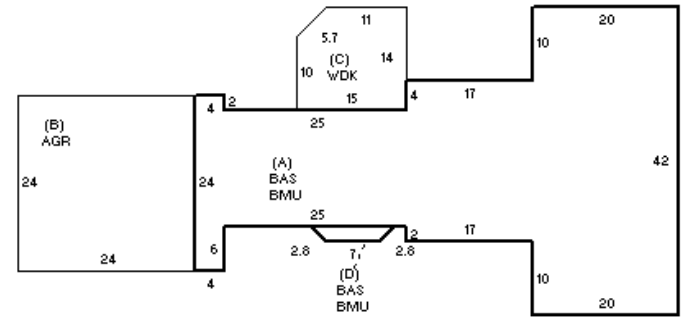

BUILDING

BUILDING	CD	ADJ	DESC	MEASURE	12/28/2017	NF
MODEL	1		RESIDENTIAL	LIST	12/28/2017	NF
STYLE	1	1.00	RANCH [100%]	REVIEW	5/23/2018	TD
QUALITY	G	1.30	GOOD [100%]			
FRAME	1	1.00	WD FRAME [100%]			

BLDG COMMENTS
GENERATOR
PULL DOWN STAIRS TO ATTIC

G

YEAR BLT	1967	SIZE ADJ	1.000	ELEMENT	CD	DESCRIPTION	ADJ	S	BAT	T	DESCRIPTION	UNITS	YB	ADJ PRICE	RCN	TOTAL RCN	708,640
NET AREA	1,728	DETAIL ADJ	1.000	FOUNDATION	4	FLR & WALL	1.00	+	BMU	N	BSMT UNFINISHED	1,728		66.50	114,910		
\$NLA(RCN)	\$410	OVERALL	1.000	EXT COVER	1	WD SHINGLE	1.00	+	BAS	L	BASE AREA	1,728	1967	307.63	531,588		
				ROOF SHAPE	1	GABLE	1.00	B	AGR	N	ATT GARAGE	576		49.31	28,401		
				ROOF COVER	1	ASPH/CMP SH	1.00	C	WDK	N	WOOD DECK	202		50.96	10,293		
				FLOOR COVER	1	HARDWOOD	1.00	F11	O	FPL 1S 10P	1		9,928.10	9,928			
				INT FINISH	2	DRYWALL	1.00										
				HEATING/COOL	2	HOT WATER	1.00										
				FUEL SOURCE	2	GAS	1.00										
																CONDITION ELEM	CD
																EXTERIOR	A
																INTERIOR	A
																KITCHEN	G
																BATHS	A
																HEAT/ELEC	A
																EFF.YR/AGE	1971 / 52
																COND	31 31 %
																FUNC	0
																ECON	0
																DEPR	31 % GD 69
																RCNLD	\$489,000