

Key: 6288

Town of BREWSTER - Fiscal Year 2025

9/17/2024 2:15 pm SEQ #: 6.519

LEGAL

LAND

DETACHED

BUILDING

CURRENT OWNER				PARCEL ID				LOCATION			
AUCLAIR CHRISTOPHER R & AUCLAIR KIMBERLY 71 ROCKY HILL ROAD BREWSTER, MA 02631				24-70-0				71 ROCKY HILL ROAD			
TRANSFER HISTORY				DOS	T	SALE PRICE	BK-PG (Cert)				
AUCLAIR CHRISTOPHER R & BYRNE DONALD A & BYRNE DONALD A & JUDITH M				11/15/2016	QS	475,000	30102-305				
				06/21/2001	F	1	13958-291				
				03/19/1999	QS	218,900	12138-194				

CLASS	CLASS%	DESCRIPTION			BN ID	BN	CARD	
1010	100	SINGLE FAMILY				1	1 of 1	
PMT NO	PMT DT	TY	DESC	AMOUNT	INSP	BY	1st	%
23-546	04/28/2023	7	ALTERATIONS	160,000	06/04/2024	TCK	100	100
1012	11/03/2021	7	ALTERATIONS	18,000	05/06/2022	TCK	100	100
332	04/24/2018	7	ALTERATIONS	16,000	07/18/2019	NF	100	100
853	11/09/2012	7	ALTERATIONS	8,700	01/29/2013	SF	100	100

CD	T	AC/SF/UN	Nbhd	St Ind	Infl	ADJ BASE	SAF	Topo	Lpi	VC	CREDIT AMT	ADJ VALUE
100	S	40,020	12	1.00	A	1.00	A	1.00				264,600

TOTAL	40,020 SF	ZONING	RL	FRNT	0	ASSESSED	CURRENT	PREVIOUS
Nbhd	NBHD 12	NOTE	LAND	264,600	249,600			
St Ind	AVERAGE		BUILDING	733,100	626,200			
Infl	AVERAGE		DETACHED	1,600	900			
			OTHER	0	0			
<b>TOTAL</b>			<b>999,300</b>	<b>876,700</b>				

TY	QUAL	COND	DIM/NOTE	YB	UNITS	ADJ PRICE	RCNLD
SHF	A	1.00	10 0.90 8X10		80	22.01	1,600



BLDG COMMENTS  
BMF=FAM RM (PER OWNER 5/6/22)

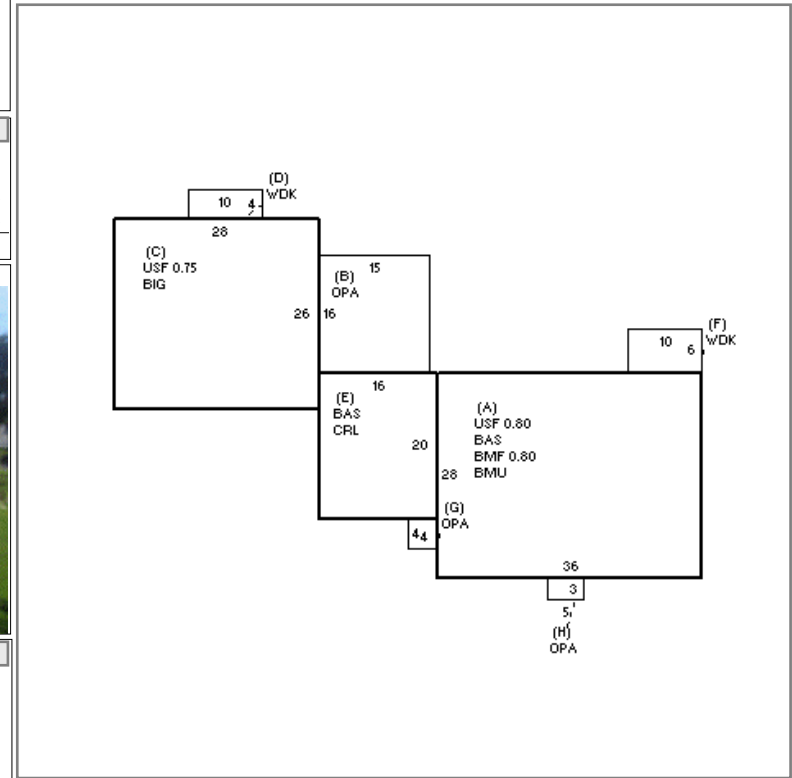

BUILDING	CD	ADJ	DESC	MEASURE	11/1/2017	NF
MODEL	1		RESIDENTIAL	LIST	7/13/2007	JH
STYLE	4	1.02	CAPE [100%]	REVIEW	6/13/2024	EMZ
QUALITY	A+	1.20	AVG + [100%]			
FRAME	1	1.00	WD FRAME [100%]			

YEAR BLT	1976	SIZE ADJ	0.990	ELEMENT	CD	DESCRIPTION	ADJ	S	BAT	T	DESCRIPTION	UNITS	YB	ADJ PRICE	RCN	
NET AREA	2,680	DETAIL ADJ	1.000	FOUNDATION	4	FLR & WALL	1.00	A	BMU	N	BSMT UNFINISHED	1,008		71.77	72,348	
\$NLA(RCN)	\$346	OVERALL	1.070	EXT COVER	1	WD SHINGLE	1.00	A	BMF	N	BSMT FINISH	806		45.25	36,475	
CAPACITY			UNITS	ADJ	ROOF SHAPE	1	GABLE	1.00	+	BAS	L	BASE AREA	1,328	1976	313.34	416,117
STORIES	1.75	1.00	ROOF COVER	1	ASPH/CMP SH	1.00	+	USF	L	UPPER STORY FIN	1,352	1976	214.62	290,170		
ROOMS	7	1.00	FLOOR COVER	2	SOFTWOOD	1.00	+	OPA	N	OPEN PORCH	271		63.56	17,224		
BEDROOMS	4	1.00	INT FINISH	2	DRYWALL	1.00	C	BIG	N	BUILT-IN GARAGE	728		60.45	44,010		
BATHROOMS	3	1.00	HEATING/COOL	11	HTWT/CL AIR	1.05	+	WDK	N	WOOD DECK	100		49.83	4,983		
FIXTURES	9	\$15,023	FUEL SOURCE	2	GAS	1.00	E	CRL	N	BSMT CRAWL	320		38.60	12,352		
GARAGE SPACES	2	1.00						F21	O	FPL 2S 1OP	1		12,903.50	12,904		
% BSMT FIN	0	1.00						GEN	O	GENERATOR	1		0.00			
# 1/2 BATHS	0	1.00						MST	O	MAS/METAL STACK	1		6,390.10	6,390		
# OF UNITS	1	1.00														

TOTAL RCN	927,995
CONDITION ELEM	CD
EXTERIOR	G
INTERIOR	G
KITCHEN	A
BATHS	G
HEAT/ELEC	G
EFF.YR/AGE	1991 / 32
COND	21 21 %
FUNC	0
ECON	0
DEPR	21 % GD 79
RCNLD	\$733,100