

Key: 6330

Town of BREWSTER - Fiscal Year 2025

9/17/2024 2:15 pm SEQ #: 6.562

LEG
AL
LAND

CURRENT OWNER		PARCEL ID		LOCATION												
CARNEVALE GARY J & MARY E 50 WINTERGREEN LANE BREWSTER, MA 02631		12-38-0		50 WINTERGREEN LANE												
TRANSFER HISTORY		DOS	T	SALE PRICE	BK-PG (Cert)											
CARNEVALE GARY J & MARY E		11/18/2019	QS	760,000	32474-336											
CHAMBERLAIN EDWARD F TRUS		02/08/2011	F	1	25242-326											
CHAMBERLAIN EDWARD F &		03/23/2006	QS	685,000	20846-280											
CD	T	AC/SF/UN	Nbhd	St Ind	Infl	ADJ BASE	SAF	Topo	Lpi	VC	CREDIT AMT	ADJ VALUE				
100	S	60,000	12	1.00	12P	1.00	A	1.00	230,160	1.00	A	1.00	R04	1.05		318,510
300	A	0.015	12	1.00	12P	1.00	A	1.00	12,600	1.00	A	1.00	R04	1.05		190

CLASS	CLASS%	DESCRIPTION		BN ID	BN	CARD	
1010	100	SINGLE FAMILY			1	1 of 1	
PMT NO	PMT DT	TY	DESC	AMOUNT	INSP	BY	1st %
24-473	05/30/2024	7	ALTERATIONS	27,911			0 0
	11/18/2019	15	SALE REVIEW	760,000	07/16/2020	JMG	100 100
		14	CYCLICAL GRO		11/07/2017	NF	100 100
718	09/19/2017	5	OTHER	2,300	06/14/2018	NF	100 100
		12	CYCLICAL NON		01/13/2011	JH	100 100

DE
T
A
C
H
E
D

TOTAL	1.392 Acres	ZONING	RL	FRNT	0	ASSESSED	CURRENT	PREVIOUS
Nbhd	NBHD 12	NOTE				LAND	318,700	300,700
St Ind	WINTERGREEN		LAND	741,400	708,200			
Infl	AVERAGE		DETACHED	50,600	50,200			
			OTHER	0	0			
						TOTAL	1,110,700	1,059,100

TY	QUAL	COND	DIM/NOTE	YB	UNITS	ADJ PRICE	RCNLD
GFL	A	1.00	10 0.90 36X24	2011	864	54.20	42,100
CPD	A	1.00	10 0.90 12X24	2011	288	11.30	2,900
HTB	A	1.00	10 0.90		1	4,058.10	3,700
SHF	A	1.00	10 0.90 8X12		96	22.01	1,900

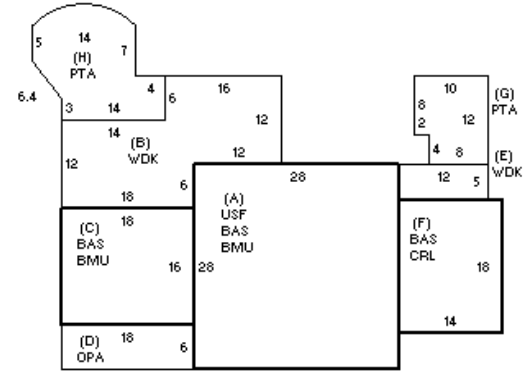

B
U
I
L
D
I
N
G

BUILDING	CD	ADJ	DESC	MEASURE	11/7/2017	NF
MODEL	1		RESIDENTIAL	LIST	1/13/2011	JH
STYLE	5	1.05	COLONIAL [100%]	REVIEW	7/16/2020	JMG
QUALITY	G	1.30	GOOD [100%]			
FRAME	1	1.00	WD FRAME [100%]			

BLDG COMMENTS

CUSTOM FEATURES

YEAR BLT	1998	SIZE ADJ	1.000	ELEMENT	CD	DESCRIPTION	ADJ	S	BAT	T	DESCRIPTION	UNITS	YB	ADJ PRICE	RCN	TOTAL RCN	842,533	
NET AREA	2,108	DETAIL ADJ	1.000	FOUNDATION	4	FLR & WALL	1.00	+	BMU	N	BSMT UNFINISHED	1,072		80.74	86,555			
\$NLA(RCN)	\$400	OVERALL	1.100	EXT COVER	1	WD SHINGLE	1.00	A	BAS	L	BASE AREA	784	1998	352.50	276,356			
				ROOF SHAPE	1	GABLE	1.00	A	USF	L	UPPER STORY FIN	784	1998	262.90	206,116			
				ROOF COVER	1	ASPH/CMP SH	1.00	+	WDK	N	WOOD DECK	444		56.06	24,889			
				FLOOR COVER	2	SOFTWOOD	1.00	C	BAS	L	BASE AREA	288	1998	352.50	101,519			
				INT FINISH	1	PLASTER	1.00	D	OPA	N	OPEN PORCH	108		71.50	7,722			
				HEATING/COOL	11	HTWT/CL AIR	1.05	F	CRL	N	BSMT CRAWL	252		43.42	10,942			
				FUEL SOURCE	2	GAS	1.00	F	BAS	L	BASE AREA	252	2000	352.49	88,829			
								G	PTA	N	PATIO	112		22.74	2,547			
								H	PTA	N	PATIO	213		20.46	4,359			
								F11	O		FPL 1S 1OP	1		10,920.90	10,921			
								ODS	O		OUTDOOR SHOWER	2		3,453.45	6,907			
																EFF.YR/AGE	2009 / 14	
																COND	12	12 %
																FUNC	0	
																ECON	0	
																DEPR	12	% GD 88
																RCNLD	\$741,400	