

Key: 6359

Town of BREWSTER - Fiscal Year 2025

9/17/2024 2:15 pm SEQ #: 6.591

LEGAL

CURRENT OWNER		PARCEL ID		LOCATION	
CORMIER LYNNE T TRUSTEE THE CORMIER FAMILY REALTY TRUST 56 EARTHBOUND CARTWAY BREWSTER, MA 02631		3-18-0		56 EARTHBOUND CARTWAY	
TRANSFER HISTORY		DOS	T	SALE PRICE	BK-PG (Cert)
CORMIER LYNNE T TRUSTEE		06/03/2016	F	100	29695-254
CORMIER LYNNE T		03/28/2013	F	100	27243-283
CORMIER DAVID F TRUSTEE		03/16/2000	F	100	12886-137

CLASS	CLASS%	DESCRIPTION		BN ID	BN	CARD	
1010	100	SINGLE FAMILY			1	1 of 1	
PMT NO	PMT DT	TY	DESC	AMOUNT	INSP	BY	1st %
NP 172	05/20/1992	12	CYCLICAL NON ADD	15,000	02/03/2008	REO RD	100 100

LAND

CD	T	AC/SF/UN	Nbhd	St Ind	Infl	ADJ BASE	SAF	Topo	Lpi	VC	CREDIT AMT	ADJ VALUE			
100	S	60,000	12	1.00	A	1.00	A	1.00	219,200	1.00	A	1.00	RM3	1.00	303,350
300	A	1,663	12	1.00	A	1.00	A	1.00	12,000	1.00	A	1.00	RM3	1.00	19,960

TOTAL	3.040 Acres	ZONING	RL	FRNT	0	ASSESSED	CURRENT	PREVIOUS
Nbhd	NBHD 12	NOTE	LAND	323,300	305,000			
St Ind	AVERAGE		BUILDING	405,400	388,000			
Infl	AVERAGE		DETACHED	1,900	1,800			
			OTHER	0	0			
			<b>TOTAL</b>	<b>730,600</b>	<b>694,800</b>			

DETACHED

TY	QUAL	COND	DIM/NOTE	YB	UNITS	ADJ PRICE	RCNLD
SHF	A	1.00	50 0.50 8X12		96	22.01	1,100
DDK	A	1.00	50 0.50 8X16		128	12.50	800

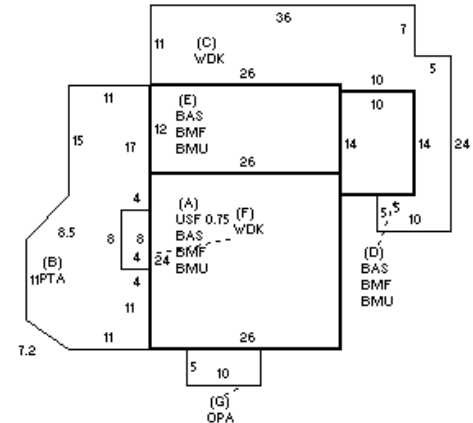

BUILDING

BUILDING	CD	ADJ	DESC	MEASURE	11/14/2017	NF
MODEL	1		RESIDENTIAL	LIST	2/3/2008	REO
STYLE	8	0.95	CONTEMPOR [100%]	REVIEW	12/14/2017	TD
QUALITY	+	1.10	PLUS AVE [100%]			
FRAME	1	1.00	WD FRAME [100%]			

BLDG COMMENTS

G

YEAR BLT	1984	SIZE ADJ	1.000	ELEMENT	CD	DESCRIPTION	ADJ	S	BAT	T	DESCRIPTION	UNITS	YB	ADJ PRICE	RCN	TOTAL RCN	540,511		
NET AREA	1,544	DETAIL ADJ	1.000	FOUNDATION	4	FLR & WALL	1.00	+	BMU	N	BSMT UNFINISHED	1,076		59.00	63,488	CONDITION ELEM	CD		
\$NLA(RCN)	\$350	OVERALL	0.950	EXT COVER	2	CLAPBOARD	1.00	+	BMF	N	BSMT FINISH	1,076		35.60	38,308	EXTERIOR	A		
CAPACITY		UNITS	ADJ	ROOF SHAPE	1	GABLE	1.00	+	BAS	L	BASE AREA	764	1984	273.05	208,609	INTERIOR	A		
STORIES		1.75	1.00	ROOF COVER	1	ASPH/CMP SH	1.00	A	USF	L	UPPER STORY FIN	468	1984	194.08	90,830	KITCHEN	A		
ROOMS		4	1.00	FLOOR COVER	1	HARDWOOD	1.00	B	PTA	N	PATIO	460		13.29	6,114	BATHS	A		
BEDROOMS		2	1.00	INT FINISH	2	DRYWALL	1.00	+	WDK	N	WOOD DECK	583		40.96	23,882	HEAT/ELEC	A		
BATHROOMS		2	1.00	HEATING/COOL	1	FORCED AIR	1.00	E	BAS	L	BASE AREA	312	1984	273.05	85,191				
FIXTURES		8	\$10,868	FUEL SOURCE	2	GAS	1.00	G	OPA	N	OPEN PORCH	50		52.25	2,613				
GARAGE SPACES		0	1.00						F21	O	FPL 2S 1OP	1		10,607.80	10,608				
% BSMT FIN		0	1.00																
# 1/2 BATHS		1	1.00																
# OF UNITS		1	1.00																
																EFF. YR/AGE	1984 / 39		
																COND	25 25 %		
																FUNC	0		
																ECON	0		
																DEPR	25	% GD	75
																RCNLD	\$405,400		