

Key: 636

Town of BREWSTER - Fiscal Year 2025

9/17/2024 2:15 pm SEQ #: 658

LEGALS AND

Table with columns: CURRENT OWNER, PARCEL ID, LOCATION, TRANSFER HISTORY, DOS, T, SALE PRICE, BK-PG (Cert). Includes owner: GREENBERG WILLIAM & ROBERTA, 197 LONGWOOD AVENUE, BROOKLINE, MA 02446.

Table with columns: CLASS, CLASS%, DESCRIPTION, BN ID, BN, CARD. Includes entries for alterations and additions with dates and amounts.

Table with columns: CD, T, AC/SF/UN, Nbhd, St Ind, Infl, ADJ BASE, SAF, Topo, Lpi, VC, CREDIT AMT, ADJ VALUE. Includes values for 100 S, 16,416 SF, etc.

Table with columns: TOTAL, 16,422 SF, ZONING, RM, FRNT, 0, ASSESSED, CURRENT, PREVIOUS. Includes assessed values for land, building, detached, and other.

Table with columns: TY, QUAL, COND, DIM/NOTE, YB, UNITS, ADJ PRICE, RCNLD. Includes entry for SHF A 1.00 30 0.70 10X10.

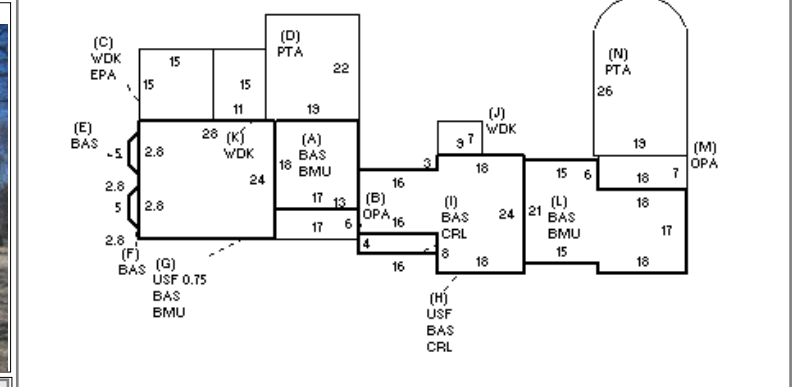

DETACHED

Table with columns: BUILDING, CD, ADJ, DESC, MEASURE, 11/5/2020, NF. Includes model, style, quality, and frame information.

Table with columns: BLDG COMMENTS.

BUILDING

Table with columns: YEAR BLT, 1984, SIZE ADJ, 0.980, NET AREA, 3,475, DETAIL ADJ, 1.000, \$NLA(RCN), \$303, OVERALL, 1.070. Includes capacity and units information.

Table with columns: ELEMENT, CD, DESCRIPTION, ADJ. Includes foundation, roof, floor, heating, and fuel source details.

Table with columns: S, BAT, T, DESCRIPTION, UNITS, YB, ADJ PRICE, RCN. Includes building components like BMU, BAS, EPA, WDK, PTA, etc.

Table with columns: TOTAL RCN, 1,052,014, CONDITION ELEM, CD. Includes exterior, interior, kitchen, baths, and heat/elec details.