

Key: 6546

Town of BREWSTER - Fiscal Year 2025

9/17/2024 2:15 pm SEQ #: 6.775

LEG  
AL  
LAND

CURRENT OWNER				PARCEL ID				LOCATION				
DROWN JEFFREY M 3668 MAIN STREET BREWSTER, MA 02631				10-59-0				25 BLACK DUCK CARTWAY				
				TRANSFER HISTORY				DOS	T	SALE PRICE	BK-PG (Cert)	
				DROWN JEFFREY M				04/24/2023	F	135745-226		
DROWN JEFFREY M TRUSTEE				06/06/2016	F	29701-295						
DROWN JEFFREY M & DONNA M				02/05/1998	QS	145,000	11208-343					

CLASS	CLASS%	DESCRIPTION		BN ID	BN	CARD	
1010	100	SINGLE FAMILY			1	1 of 1	
PMT NO	PMT DT	TY	DESC	AMOUNT	INSP	BY	1st %
541	10/06/2022	30	ABATEMENT RE		10/18/2022	JMG	100 100
704	06/20/2016	77	SOLAR PANELS	155,000	03/09/2017	NF	100 100
142	10/25/2007	2	ADD	125,000	02/03/2009	JH	100 100
142	03/05/2002	10	INGROUND POO	20,000			100 100
646	11/30/1998	5	OTHER	6,000	07/20/1999	JB	100 100

CD	T	AC/SF/UN	Nbhd	St Ind	Infl	ADJ BASE	SAF	Topo	Lpi	VC	CREDIT AMT	ADJ VALUE				
100	S	60,000	12	1.00	A	1.00	A	1.00	416,480	1.00	A	1.00	PF4	1.90		576,360
300	A	3,423	12	1.00	A	1.00	A	1.00	22,800	1.00	A	1.00	PF4	1.90		78,040

TOTAL	4.800 Acres		ZONING	RR	FRNT	0		ASSESSED	CURRENT	PREVIOUS
Nbhd	NBHD 12		N O T E	124.8 KWH Solar Array - combined power produced does not exceed 125% of aggregate electricity needs				LAND	654,400	617,300
St Ind	AVERAGE			LAND BUILDING DETACHED	980,900	925,900				
Infl	AVERAGE			OTHER	45,400	45,000				
								TOTAL	1,680,700	1,588,200

TY	QUAL	COND	DIM/NOTE	YB	UNITS	ADJ PRICE	RCNLD
PLH	A	1.00	50 0.50 16X20		320	41.91	6,700
IPG	G	1.20	01 1.00 18X36		648	55.28	35,800
PTD	G	1.20	01 1.00 16X20		320	9.18	2,900
PVS	SV	1.00	NV 0.00 GM 124.8 KW	2016		0.00	

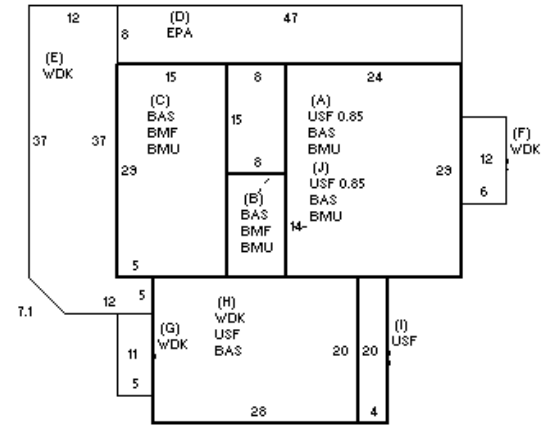

BUILDING	CD	ADJ	DESC	MEASURE	3/19/2008	JH
MODEL	1		RESIDENTIAL	LIST	3/19/2008	JH
STYLE	4	1.02	CAPE [100%]	REVIEW	4/12/2017	TD
QUALITY	G	1.30	GOOD [100%]	440 SOLAR PANELS GROUND MOUNT		
FRAME	1	1.00	WD FRAME [100%]			

DET  
ACHED

B  
U  
I  
L  
D  
I  
N  
G

YEAR BLT	1998	SIZE ADJ	0.980	ELEMENT	CD	DESCRIPTION	ADJ	S	BAT	T	DESCRIPTION	UNITS	YB	ADJ PRICE	RCN	TOTAL RCN	1,114,672				
NET AREA	3,250	DETAIL ADJ	1.000	FOUNDATION	4	FLR & WALL	1.00	+	BMU	N	BSMT UNFINISHED	1,363		70.61	96,245	CONDITION ELEM CD					
\$NLA(RCN)	\$343	OVERALL	1.020	EXT COVER	14	OTHER	1.00	+	BAS	L	BASE AREA	808	1998	294.70	238,114	EXTERIOR	G				
				ROOF SHAPE	1	GABLE	1.00	+	USF	L	UPPER STORY FIN	687	1998	219.40	150,731	INTERIOR	G				
				ROOF COVER	1	ASPH/CMP SH	1.00	+	BMF	N	BSMT FINISH	555		52.41	29,090	KITCHEN	A				
				FLOOR COVER	2	SOFTWOOD	1.00	+	BAS	L	BASE AREA	555	1998	294.70	163,557	BATHS	A				
				INT FINISH	3	WD PANEL	1.00	D	EPA	N	ENCLOSED PORCH	376		88.92	33,433	HEAT/ELEC	A				
				HEATING/COOL	3	RADIANT	1.00	+	WDK	N	WOOD DECK	1,204		50.94	61,332						
				FUEL SOURCE	1	OIL	1.00	H	BAS	L	BASE AREA	560	2007	294.70	165,030						
												+	USF	L	UPPER STORY FIN	640	2007	219.41	140,419		
													F21	O	FPL 2S 1OP	1		13,191.00	13,191		
													ODS	O	OUTDOOR SHOWER	1		3,138.20	3,138		
													WPL	O	WHIRLPOOL	1		10,050.20	10,050		
												EFF.YR/AGE		2009 / 14							
				CAPACITY		UNITS	ADJ									COND	12	12 %			
				STORIES		1.75	1.00									FUNC	0				
				ROOMS		7	1.00									ECON	0				
				BEDROOMS		2	1.00									DEPR	12	% GD	88		
				BATHROOMS		2	1.00									RCNLD	\$980,900				
				FIXTURES		6	\$10,343														
				GARAGE SPACES		0	1.00														
				% BSMT FIN		0	1.00														
				# 1/2 BATHS		0	1.00														
				# OF UNITS		1	1.00														