

Key: 6639

Town of BREWSTER - Fiscal Year 2025

9/17/2024 2:15 pm SEQ #: 6.864

LEGALS

CURRENT OWNER		PARCEL ID		LOCATION	
HANSON DANIEL R HANSON SANDRA W 50 PINE VIEW DRIVE BREWSTER, MA 02631		10-46-0		50 PINE VIEW DRIVE	
TRANSFER HISTORY		DOS	T	SALE PRICE	BK-PG (Cert)
HANSON DANIEL R		02/18/1992	QS	186,000	7880-021

CLASS	CLASS%	DESCRIPTION		BN ID	BN	CARD	
1010	100	SINGLE FAMILY			1	1 of 1	
PMT NO	PMT DT	TY	DESC	AMOUNT	INSP	BY	1st %
272 NP	07/06/2009	7	ALTERATIONS	4,000	04/06/2010	JH	100 100
285	05/10/2000	7	CYCLICAL NON ALTERATIONS	10,000	03/07/2008	JH	100 100

LAND

CD	T	AC/SF/UN	Nbhd	St Ind	Infl	ADJ BASE	SAF	Topo	Lpi	VC	CREDIT AMT	ADJ VALUE
100	S	23,500	12	1.00	12Q 1.00 A 1.00	274,000	1.95	A	1.00	PV6	1.25	287,940

TOTAL	23,500 SF	ZONING	RR	FRNT	0	ASSESSED	CURRENT	PREVIOUS
Nbhd	NBHD 12	N O N E	POND VIEW			LAND	287,900	271,700
St Ind	SLOUGH		BUILDING	508,800	486,600			
Infl	AVERAGE		DETACHED	1,100	1,000			
			OTHER	0	0			
						TOTAL	797,800	759,300

DETAILED

TY	QUAL	COND	DIM/NOTE	YB	UNITS	ADJ PRICE	RCNLD
SHF	A	1.00 50 0.50	8X12		96	22.01	1,100

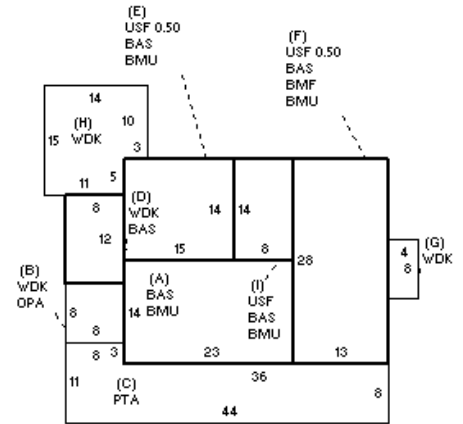

BUILDING

BUILDING	CD	ADJ	DESC	MEASURE	12/6/2017	NF
MODEL	1		RESIDENTIAL	LIST	3/20/2008	JH
STYLE	4	1.02	CAPE [100%]	REVIEW	4/7/2010	SEJ
QUALITY	G	1.30	GOOD [100%]			
FRAME	1	1.00	WD FRAME [100%]			

BLDG COMMENTS

G

YEAR BLT	1988	SIZE ADJ	1.000	ELEMENT	CD	DESCRIPTION	ADJ	S	BAT	T	DESCRIPTION	UNITS	YB	ADJ PRICE	RCN	TOTAL RCN	644,083		
NET AREA	1,503	DETAIL ADJ	1.000	FOUNDATION	4	FLR & WALL	1.00	+	BMU	N	BSMT UNFINISHED	1,008		77.81	78,429	CONDITION ELEM	CD		
\$NLA(RCN)	\$429	OVERALL	1.060	EXT COVER	2	CLAPBOARD	1.00	A	BAS	L	BASE AREA	322	1988	349.87	112,657	EXTERIOR	G		
				ROOF SHAPE	1	GABLE	1.00	B	OPA	N	OPEN PORCH	64		68.90	4,410	INTERIOR	A		
				ROOF COVER	2	WD SHINGLE	1.01	C	PTA	N	PATIO	376		18.63	7,003	KITCHEN	A		
				FLOOR COVER	1	HARDWOOD	1.00	+	BAS	L	BASE AREA	782	1988	349.87	273,596	BATHS	A		
				INT FINISH	2	DRYWALL	1.00	+	USF	L	UPPER STORY FIN	399	1988	255.93	102,115	HEAT/ELEC	A		
				HEATING/COOL	9	WARM/CL AIR	1.03	F	BMF	N	BSMT FINISH	364		55.58	20,232				
				FUEL SOURCE	2	GAS	1.00	+	WDK	N	WOOD DECK	387		54.02	20,904				
									F21	O	FPL 2S 10P	1		13,988.10	13,988				
CAPACITY		UNITS	ADJ															EFF.YR/AGE	1991 / 32
STORIES	1.5	1.00																COND	21 21 %
ROOMS	6	1.00																FUNC	0
BEDROOMS	3	1.00																ECON	0
BATHROOMS	2	1.00																DEPR	21 % GD 79
FIXTURES	6	\$10,748																RCNLD	\$508,800
GARAGE SPACES	0	1.00																	
% BSMT FIN	30	1.00																	
# 1/2 BATHS	0	1.00																	
# OF UNITS	1	1.00																	