

Key: 6653

Town of BREWSTER - Fiscal Year 2025

9/17/2024 2:15 pm SEQ #: 6.878

LEGAL

CURRENT OWNER		PARCEL ID	LOCATION		
MCLAUGHLIN GEORGE E III & MICHELLE E 158 TURNING MILL ROAD BREWSTER, MA 02631		33-13-0	158 TURNING MILL ROAD		
TRANSFER HISTORY		DOS	T	SALE PRICE	BK-PG (Cert)
MCLAUGHLIN GEORGE E III & CHUNG PETER TARIM & BAKER		10/25/2021	QS	730,000	(228014)
FALCONETT JEROME J & SARA		06/07/2002	QS	130,000	(165519)
		10/25/1985	XX		(103915)

CLASS	CLASS%	DESCRIPTION			BN ID	BN	CARD	
1010	100	SINGLE FAMILY				1	1 of 1	
PMT NO	PMT DT	TY	DESC	AMOUNT	INSP	BY	1st	%
494	10/25/2021	16	MLS REVIEW	730,000	06/07/2022	JMG	100	100
	08/31/2005	1	NEW CONSTRUC	200,000	06/13/2006	JB	100	100

LAND

CD	T	AC/SF/UN	Nbhd	St Ind	Infl	ADJ BASE	SAF	Topo	Lpi	VC	CREDIT AMT	ADJ VALUE
100	S	20,005	12 1.00	12N 1.00	A 1.00	230,160	2.21	A	1.00	R04	1.05	233,910

TOTAL	20,005 SF	ZONING	RR	FRNT	0	ASSESSED	CURRENT	PREVIOUS
Nbhd	NBHD 12	NOTE Street address from building permit.	LAND	233,900	220,700			
St Ind	MILL POND		BUILDING	465,500	439,600			
Infl	AVERAGE		DETACHED	0	0			
			OTHER	0	0			
			TOTAL	699,400	660,300			

DETACHED

TY	QUAL	COND	DIM/NOTE	YB	UNITS	ADJ PRICE	RCNLD

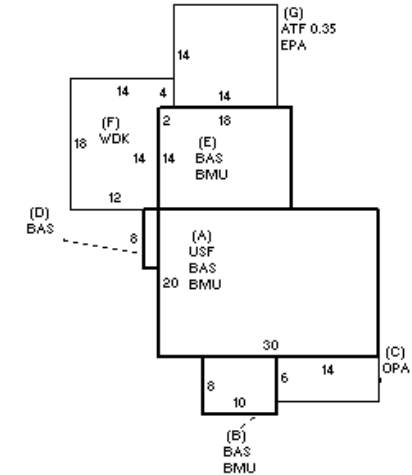

BLDG COMMENTS

BUILDING

BUILDING	CD	ADJ	DESC	MEASURE	10/5/2017	NF
MODEL	1		RESIDENTIAL	LIST	12/14/2007	REO
STYLE	5	1.05	COLONIAL [100%]	REVIEW	6/7/2022	JMG
QUALITY	+	1.10	PLUS AVE [100%]			
FRAME	1	1.00	WD FRAME [100%]			

YEAR BLT	2005	SIZE ADJ	1.000	ELEMENT	CD	DESCRIPTION	ADJ	S	BAT	T	DESCRIPTION	UNITS	YB	ADJ PRICE	RCN	TOTAL RCN	541,261
NET AREA	1,548	DETAIL ADJ	1.000	FOUNDATION	4	FLR & WALL	1.00	+	BMU	N	BSMT UNFINISHED	932		68.14	63,511	CONDITION ELEM	CD
\$NLA(RCN)	\$350	OVERALL	1.050	EXT COVER	1	WD SHINGLE	1.00	A	USF	L	UPPER STORY FIN	600	2005	214.51	128,706	EXTERIOR	A
				ROOF SHAPE	1	GABLE	1.00	C	OPA	N	OPEN PORCH	84		57.75	4,851	INTERIOR	A
				ROOF COVER	1	ASPH/CMP SH	1.00	+	BAS	L	BASE AREA	948	2005	307.48	291,495	KITCHEN	A
				FLOOR COVER	1	HARDWOOD	1.00	F	WDK	N	WOOD DECK	224		45.28	10,142	BATHS	A
				INT FINISH	2	DRYWALL	1.00	G	EPA	N	ENCLOSED PORCH	196		88.33	17,312	HEAT/ELEC	A
				HEATING/COOL	1	FORCED AIR	1.00	G	ATF	N	ATTIC FINISH	69		88.93	6,137		
				FUEL SOURCE	2	GAS	1.00	MST	O		MAS/METAL STACK	1		5,806.20	5,806		
								ODS	O		OUTDOOR SHOWER	1		2,789.30	2,789		
CAPACITY		UNITS	ADJ														
STORIES		2	1.00														
ROOMS		5	1.00														
BEDROOMS		3	1.00														
BATHROOMS		2	1.00														
FIXTURES		7	\$10,511														
GARAGE SPACES		0	1.00														
% BSMT FIN		0	1.00														
# 1/2 BATHS		0	1.00														
# OF UNITS		1	1.00														
EFF.YR/AGE		2005 / 18															
COND	14	14 %															
FUNC	0																
ECON	0																
DEPR	14	% GD	86														
RCNLD			\$465,500														