

Key: 6660

Town of BREWSTER - Fiscal Year 2025

9/17/2024 2:15 pm SEQ #: 6.885

LEGAL

LAND

DETACHED

BUILDING

CURRENT OWNER				PARCEL ID				LOCATION			
GOODYEAR LAURA J 17 LEDGE HILL ROAD SOUTHBOROUGH, MA 01772				33-30-0				72 TURNING MILL ROAD			
TRANSFER HISTORY				DOS	T	SALE PRICE	BK-PG (Cert)				
GOODYEAR LAURA J				03/06/2019	F	100	(218755)				
CHASE LARRY &				06/19/2008	A	650,000	(186254)				
GOODYEAR ALAN H TRUSTEE				01/15/2004	F		(171858)				

CLASS	CLASS%	DESCRIPTION		BN ID	BN	CARD	
1010	100	SINGLE FAMILY			1	1 of 1	
PMT NO	PMT DT	TY	DESC	AMOUNT	INSP	BY	1st %
902	10/04/2016	14	CYCLICAL GRO		10/05/2017	NF	100 100
207	07/02/1990	7	ALTERATIONS	9,600	03/27/2017	NF	100 100
		5	OTHER	4,000	03/13/1991		100 100

CD	T	AC/SF/UN	Nbhd	St Ind	Infl	ADJ BASE	SAF	Topo	Lpi	VC	CREDIT AMT	ADJ VALUE
100	S	20,080	12	1.00	12N 1.00 A 1.00	416,480	2.21	A	1.00	PF4	1.90	423,600

TOTAL	20,080 SF	ZONING	RR	FRNT	0	ASSESSED	CURRENT	PREVIOUS
Nbhd	NBHD 12	NOTE	LAND	423,600	399,600			
St Ind	MILL POND		BUILDING	581,200	556,300			
Infl	AVERAGE		DETACHED	800	800			
			OTHER	0	0			
			<b>TOTAL</b>	<b>1,005,600</b>	<b>956,700</b>			

TY	QUAL	COND	DIM/NOTE	YB	UNITS	ADJ PRICE	RCNLD
PTD	A	1.00	20 0.80 12X8		96	10.35	800



PHOTO 10/05/2017

BLDG COMMENTS

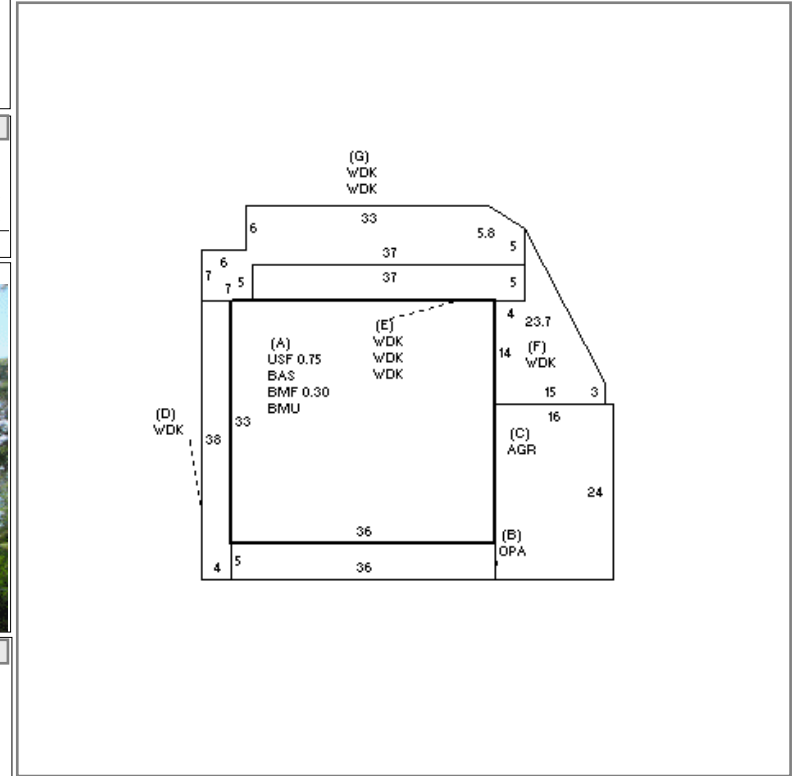

BUILDING	CD	ADJ	DESC	MEASURE	10/5/2017	NF
MODEL	1		RESIDENTIAL	LIST	10/5/2017	EST
STYLE	4	1.02	CAPE [100%]	REVIEW	11/15/2017	TD
QUALITY	+	1.10	PLUS AVE [100%]			
FRAME	1	1.00	WD FRAME [100%]			

YEAR BLT	1984	SIZE ADJ	1.000	ELEMENT	CD	DESCRIPTION	ADJ	S	BAT	T	DESCRIPTION	UNITS	YB	ADJ PRICE	RCN
NET AREA	2,079	DETAIL ADJ	1.000	FOUNDATION	4	FLR & WALL	1.00	A	BMU	N	BSMT UNFINISHED	1,188		66.46	78,951
\$NLA(RCN)	\$373	OVERALL	1.070	EXT COVER	1	WD SHINGLE	1.00	A	BMF	N	BSMT FINISH	356		47.47	16,901
				ROOF SHAPE	1	GABLE	1.00	A	BAS	L	BASE AREA	1,188	1984	298.83	355,015
				ROOF COVER	1	ASPH/CMP SH	1.00	A	USF	L	UPPER STORY FIN	891	1984	214.18	190,835
				FLOOR COVER	3	W/W CARPET	1.00	B	OPA	N	OPEN PORCH	180		58.85	10,593
				INT FINISH	2	DRYWALL	1.00	C	AGR	N	ATT GARAGE	384		48.70	18,700
				HEATING/COOL	11	HTWT/CL AIR	1.05	+	WDK	N	WOOD DECK	1,600		46.14	73,821
				FUEL SOURCE	1	OIL	1.00		F21	O	FPL 2S 1OP	1		11,947.70	11,948
									ODS	O	OUTDOOR SHOWER	1		2,842.50	2,843

TOTAL RCN	774,907
CONDITION ELEM	CD
EXTERIOR	A
INTERIOR	A
KITCHEN	A
BATHS	A
HEAT/ELEC	A
EFF.YR/AGE	1984 / 39
COND	25 25 %
FUNC	0
ECON	0
DEPR	25 % GD 75
RCNLD	\$581,200