

Key: 6693

Town of BREWSTER - Fiscal Year 2025

9/17/2024 2:15 pm SEQ #: 6.919

LEG
A
L

CURRENT OWNER		PARCEL ID		LOCATION	
BEARD KEVIN N & CARRIE A 42 TURNING MILL ROAD BREWSTER, MA 02631		33-33-0		42 TURNING MILL ROAD	
TRANSFER HISTORY		DOS	T	SALE PRICE	BK-PG (Cert)
BEARD KEVIN N & CARRIE A		10/07/2015	QS	1,115,000	(207578)
WILLIAMS DENIS G & CHERYL		05/02/2002	P	265,000	(165126)
JEPSEN JOHN H & PAMELA N		10/30/1998	QS	127,000	(150681)

CLASS	CLASS%	DESCRIPTION		BN ID	BN	CARD	
1010	100	SINGLE FAMILY			1	1 of 1	
PMT NO	PMT DT	TY	DESC	AMOUNT	INSP	BY	1st %
91	02/02/2017	77	SOLAR PANELS	44,200	10/19/2017	NF	100 100
828	09/13/2016	3	OUT BUILDING	6,300	03/27/2017	NF	100 100
394	07/20/2005	3	OUT BUILDING	900			100 100
490	08/12/2003	5	OTHER	20,000	08/03/2004	WH	100 100
514	09/09/2002	1	NEW CONSTRUC	326,000	08/04/2004	WH	100 100

L
A
N
D

CD	T	AC/SF/UN	Nbhd	St Ind	Infl	ADJ BASE	SAF	Topo	Lpi	VC	CREDIT AMT	ADJ VALUE
100	S	51,260	12	1.00	12N 1.00 A 1.00	395,656	1.12	5	0.95	PF4	1.90	520,070

TOTAL	1.177 Acres	ZONING	RR	FRNT	0	ASSESSED	CURRENT	PREVIOUS
Nbhd	NBHD 12	N O T E	T=ASSOC BEACH/EASEMENT			LAND	520,100	490,700
St Ind	MILL POND		BUILDING	1,152,700	1,101,700			
Infl	AVERAGE		DETACHED	5,100	5,100			
			OTHER	0	0			
TOTAL						1,677,900	1,597,500	

D
E
T
A
C
H
E
D

TY	QUAL	COND	DIM/NOTE	YB	UNITS	ADJ PRICE	RCNLD
SHF	A	1.00	20 0.80	8X14	2016	112 21.39	1,900
HTB	A	1.00	20 0.80			1 4,058.10	3,200



PHOTO 10/04/2017

BLDG COMMENTS
35 SOLAR PANELS EST

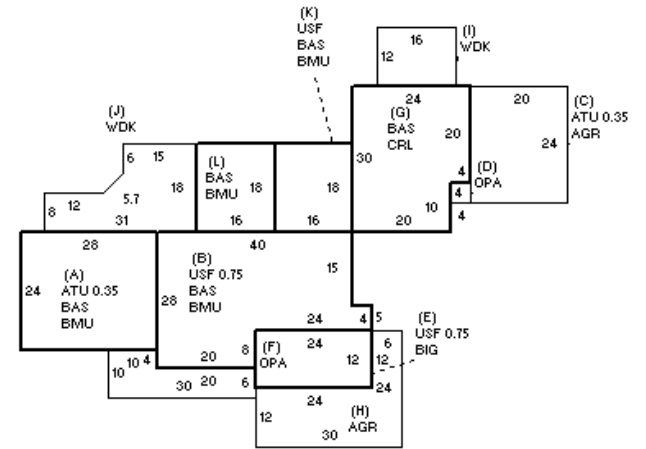

B
U
I
L
D
I
N
G

BUILDING	CD	ADJ	DESC	MEASURE	10/4/2017	NF
MODEL	1		RESIDENTIAL	LIST	12/31/2007	REO
STYLE	8	0.95	CONTEMPOR [100%]	REVIEW	11/14/2017	TD
QUALITY	G	1.30	GOOD [100%]			
FRAME	1	1.00	WD FRAME [100%]			

YEAR BLT	2002	SIZE ADJ	0.970
NET AREA	4,147	DETAIL ADJ	1.000
\$NLA(RCN)	\$331	OVERALL	0.980

ELEMENT	CD	DESCRIPTION	ADJ
FOUNDATION	4	FLR & WALL	1.00
EXT COVER	1	WD SHINGLE	1.00
ROOF SHAPE	1	GABLE	1.00
ROOF COVER	1	ASPH/CMP SH	1.00
FLOOR COVER	1	HARDWOOD	1.00
INT FINISH	1	PLASTER	1.00
HEATING/COOL	9	WARM/CL AIR	1.03
FUEL SOURCE	2	GAS	1.00

S	BAT	T	DESCRIPTION	UNITS	YB	ADJ PRICE	RCN
+	BMU	N	BSMT UNFINISHED	2,228		56.72	126,383
+	BAS	L	BASE AREA	2,908	2002	274.16	797,251
A	ATU	N	ATTIC UNF	235		65.99	15,508
+	USF	L	UPPER STORY FIN	1,239	2002	208.65	258,517
C	AGR	N	ATT GARAGE	480		49.00	23,521
C	ATU	N	ATTIC UNF	168		65.99	11,086
+	OPA	N	OPEN PORCH	236		61.79	14,582
E	BIG	N	BUILT-IN GARAGE	288		68.34	19,681
G	CR L	N	BSMT CRAWL	680		34.97	23,783
H	AGR	N	ATT GARAGE	432		50.07	21,629
+	W/DK	N	WOOD DECK	598		48.44	28,969
GFP	O		GAS FIREPLACE	1		3,863.00	3,863
KIT	O		XTRA KITCHEN	1		2,681.60	2,682

TOTAL RCN	1,372,297
CONDITION ELEM	CD
EXTERIOR	A
INTERIOR	A
KITCHEN	A
BATHS	A
HEAT/ELEC	A
EFF.YR/AGE	2002 / 21
COND	16 16 %
FUNC	0
ECON	0
DEPR	16 % GD 84
RCNLD	\$1,152,700