

Key: 6706

Town of BREWSTER - Fiscal Year 2025

9/17/2024 2:15 pm SEQ #: 6.932

LEGAL

CURRENT OWNER				PARCEL ID				LOCATION			
BITTRICH CHRISTINE TRUSTEE & BITTRICH MICHAEL TRUSTEE				44-6-0				81 MISTY LANE			
81 MISTY LANE BREWSTER, MA 02631				TRANSFER HISTORY				DOS	T	SALE PRICE	BK-PG (Cert)
				BITTRICH CHRISTINE TRUSTE				12/12/2022	F	1 (231788)	
				BITTRICH CHRISTINE TRUSTE				10/18/2012	F	100 (129397)	
				BITTRICH MICHAEL & CHRIST				02/23/1993	QS	42,000 (129397)	

CLASS	CLASS%	DESCRIPTION			BN ID	BN	CARD	
1010	100	SINGLE FAMILY				1	1 of 1	
PMT NO	PMT DT	TY	DESC	AMOUNT	INSP	BY	1st	%
485	08/03/2020	7	ALTERATIONS	4,100	01/05/2021	NF	100	100
267	10/31/2019	30	ABATEMENT RE		12/05/2019	JMG	100	100
427	05/22/2001	5	OTHER	10,000	06/19/2001	LB	100	100
171	07/24/2000	5	OTHER	5,000	06/19/2001	LB	100	100
	04/05/2000	1	NEW CONSTRUC	350,000	06/19/2001	LB	100	100

LAND

TOTAL	1.010 Acres	ZONING	RR	FRNT	0	ASSESSED	CURRENT	PREVIOUS
Nbhd	NBHD 12	NOTE				LAND	286,700	270,500
St Ind	DEERFIELD SUB					BUILDING	1,033,500	976,300
Infl	AVERAGE					DETACHED	0	0
						OTHER	0	0
						TOTAL	1,320,200	1,246,800

DETACHED

TY	QUAL	COND	DIM/NOTE	YB	UNITS	ADJ PRICE	RCNLD	PHOTO
								09/28/2017

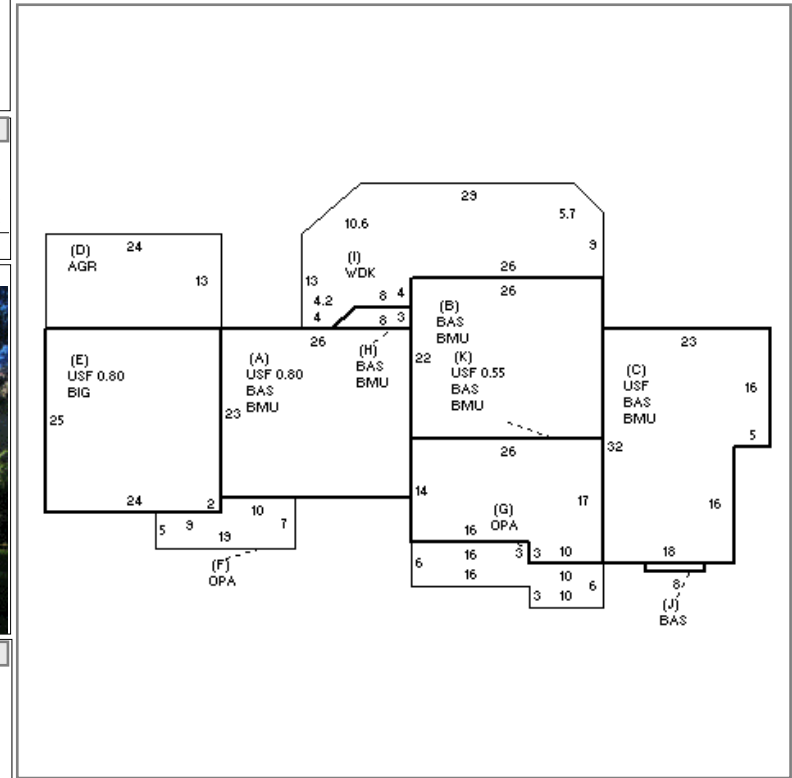
BUILDING

BUILDING	CD	ADJ	DESC	MEASURE	12/5/2019	JMG
MODEL	1		RESIDENTIAL	LIST	12/5/2019	JMG
STYLE	8	0.95	CONTEMPOR [100%]	REVIEW	1/27/2021	MR
QUALITY	G	1.30	GOOD [100%]			
FRAME	1	1.00	WD FRAME [100%]			

BLDG COMMENTS  
Master Bath = 5 Fixtures, 1 Full Bath = 4 Fixtures, 1 Full Bath = 3 Fixtures, 2 Half Baths; PULL DOWN STAIRS TO ATTIC

G

YEAR BLT	2001	SIZE ADJ	0.970	ELEMENT	CD	DESCRIPTION	ADJ	S	BAT	T	DESCRIPTION	UNITS	YB	ADJ PRICE	RCN	TOTAL RCN	1,230,387
NET AREA	4,088	DETAIL ADJ	1.000	FOUNDATION	4	FLR & WALL	1.00	+	BMU	N	BSMT UNFINISHED	2,249		56.72	127,575		
\$NLA(RCN)	\$301	OVERALL	0.980	EXT COVER	1	WD SHINGLE	1.00	+	USF	L	UPPER STORY FIN	1,831	2001	190.10	348,077		
				ROOF SHAPE	1	GABLE	1.00	B	BAS	L	BASE AREA	572	2001	274.16	156,818		
				ROOF COVER	1	ASPH/CMP SH	1.00	D	AGR	N	ATT GARAGE	312		52.20	16,285		
				FLOOR COVER	3	W/W CARPET	1.00	E	BIG	N	BUILT-IN GARAGE	600		60.14	36,082		
				INT FINISH	2	DRYWALL	1.00	+	OPA	N	OPEN PORCH	271		61.79	16,745		
				HEATING/COOL	9	WARM/CL AIR	1.03	I	WDK	N	WOOD DECK	574		48.44	27,806		
				FUEL SOURCE	1	OIL	1.00	+	BAS	L	BASE AREA	1,685	2001	274.16	461,956		
									F21	O	FPL 2S 1OP	1		12,544.40	12,544		

CONDITION ELEM	CD
EXTERIOR	A
INTERIOR	A
KITCHEN	A
BATHS	A
HEAT/ELEC	A

EFF.YR/AGE	2001 / 22
COND	16 16 %
FUNC	0
ECON	0
DEPR	16 % GD 84
RCNLD	\$1,033,500