

Key: 6874

Town of BREWSTER - Fiscal Year 2025

9/17/2024 2:15 pm SEQ #: 7.099

LEGAL

LAND

DETACHED

BUILDING

CURRENT OWNER				PARCEL ID				LOCATION			
BECOTTE DANIEL G & GRACE 744 HARWICH ROAD BREWSTER, MA 02631				63-5-0				744 HARWICH ROAD			
TRANSFER HISTORY				DOS	T	SALE PRICE	BK-PG (Cert)				
BECOTTE DANIEL G & GRACE				11/29/2010	U	245,000	25040-24				
MACKLIN DENNIS K & SHARRO				11/15/1978	XX		2820-136				

CLASS	CLASS%	DESCRIPTION			BN ID	BN	CARD	
1010	100	SINGLE FAMILY				1	1 of 1	
PMT NO	PMT DT	TY	DESC	AMOUNT	INSP	BY	1st	%
262	03/25/2021	2	ADD		06/03/2024	TCK	10	100
854	12/01/2020	7	ALTERATIONS	10,000	05/03/2022	TCK	100	100
463	05/30/2018	7	ALTERATIONS	20,000	06/03/2024	TCK	100	100
692	07/28/2016	7	ALTERATIONS	5,000	04/11/2019	NF	100	100

CD	T	AC/SF/UN	Nbhd	St Ind	Infl	ADJ BASE	SAF	Topo	Lpi	VC	CREDIT AMT	ADJ VALUE				
100	S	30,185	12	1.00	12D	1.00	A	1.00	219,200	1.61	A	1.00	RM4	1.00		244,320

TOTAL	30,185 SF	ZONING	RM	FRNT	0	ASSESSED	CURRENT	PREVIOUS
Nbhd	NBHD 12	NOTE	LAND	244,300	230,500			
St Ind	HARWICH ROAD		BUILDING	428,000	404,100			
Infl	AVERAGE		DETACHED	5,200	5,100			
			OTHER	0	0			
TOTAL				677,500	639,700			

TY	QUAL	COND	DIM/NOTE	YB	UNITS	ADJ PRICE	RCNLD
SHF	A	1.00	30 0.70 8X10		80	22.01	1,200
GHD	A	1.00	30 0.70 UC 13X13	2021	169	33.39	4,000



BLDG COMMENTS
BMF= BDRM 20X10 INFO@DOOR 1/15/21

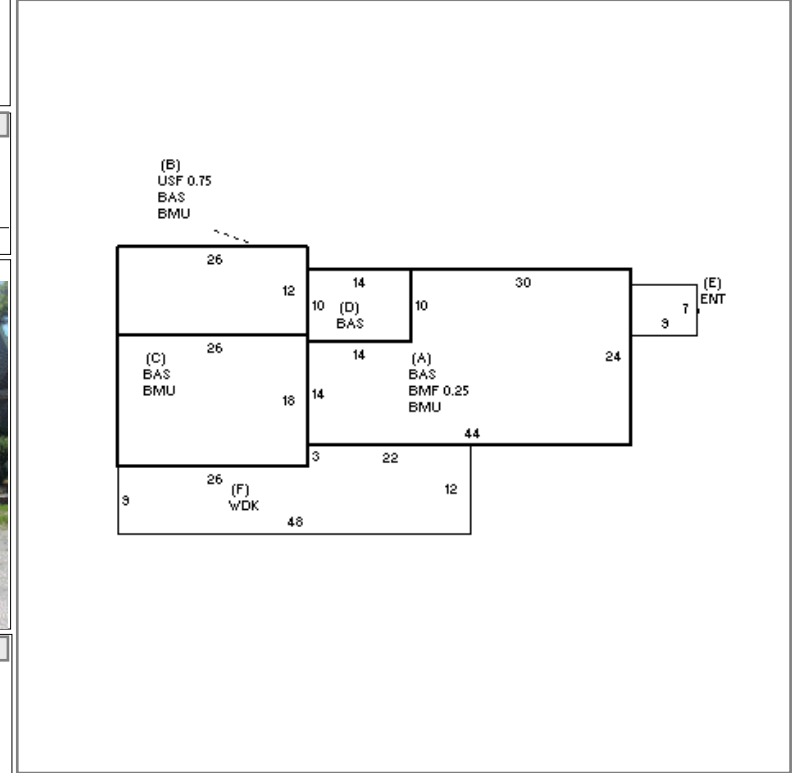

BUILDING	CD	ADJ	DESC	MEASURE	4/11/2019	NF
MODEL	1		RESIDENTIAL	LIST	3/22/2017	NF
STYLE	8	0.95	CONTEMPOR [100%]	REVIEW	6/13/2024	EMZ
QUALITY	A	1.00	AVG [100%]			
FRAME	1	1.00	WD FRAME [100%]			

YEAR BLT	1961	SIZE ADJ	1.000	ELEMENT	CD	DESCRIPTION	ADJ	S	BAT	T	DESCRIPTION	UNITS	YB	ADJ PRICE	RCN	TOTAL RCN	541,736
NET AREA	2,070	DETAIL ADJ	1.000	FOUNDATION	4	FLR & WALL	1.00	+	BMU	N	BSMT UNFINISHED	1,696		46.04	78,080	CONDITION ELEM	CD
\$NLA(RCN)	\$262	OVERALL	0.900	EXT COVER	1	WD SHINGLE	1.00	A	BMF	N	BSMT FINISH	229		36.30	8,313	EXTERIOR	G
				ROOF SHAPE	1	GABLE	1.00	+	BAS	L	BASE AREA	1,228	1961	208.54	256,086	INTERIOR	V
				ROOF COVER	1	ASPH/CMP SH	1.00	B	USF	L	UPPER STORY FIN	234	1961	167.15	39,113	KITCHEN	V
				FLOOR COVER	1	HARDWOOD	1.00	C	BAS	L	BASE AREA	468	1961	208.54	97,596	BATHS	V
				INT FINISH	5	MIN/OTHER	0.95	D	BAS	L	BASE AREA	140	2018	208.54	29,195	HEAT/ELEC	A
				HEATING/COOL	2	HOT WATER	1.00	E	ENT	N	ENCLOSED ENTRY	63		104.60	6,590		
				FUEL SOURCE	2	GAS	1.00	F	WDK	N	WOOD DECK	498		35.28	17,570		
									GEN	O	GENERATOR	1		0.00			
									ODS	O	OUTDOOR SHOWER	1		2,173.50	2,174		
													EFF.YR/AGE	1993 / 30			
													COND	20 20 %			
													FUNC	1 UC			
													ECON	0			
													DEPR	21 % GD 79			
													RCNLD	\$428,000			