

Key: 6943

Town of BREWSTER - Fiscal Year 2025

9/17/2024 2:15 pm SEQ #: 7.169

LEGALS

CURRENT OWNER				PARCEL ID				LOCATION			
MOROS FRANCOISE TRUSTEE THE FRANCOISE MOROS FAMILY TRUST OF 1992 41 GROVE STREET WINCHESTER, MA 01890				43-9-0				137 SURREY LANE			
TRANSFER HISTORY				DOS	T	SALE PRICE	BK-PG (Cert)				
MOROS FRANCOISE TRUSTEE				01/03/2020	F	1	32597-86				
MOROS DAVID & FRANCOISE				10/28/1988	XX	297,500	6499-239				

CLASS	CLASS%	DESCRIPTION			BN ID	BN	CARD	
1010	100	SINGLE FAMILY				1	1 of 1	
PMT NO	PMT DT	TY	DESC	AMOUNT	INSP	BY	1st	%
417		14	CYCLICAL GRO		08/29/2017	NF	100	100
240	05/16/2013	7	ALTERATIONS	20,000	08/21/2014	RJM	100	100
42	05/26/2010	3	OUT BUILDING	800	01/04/2011	MR	100	100
473	02/17/2009	7	ALTERATIONS	4,000	04/13/2010	JH	100	100
	08/11/2003	3	OUT BUILDING	4,000	04/30/2007	JH	100	100

LAND

CD	T	AC/SF/UN	Nbhd	St Ind	Infl	ADJ BASE	SAF	Topo	Lpi	VC	CREDIT AMT	ADJ VALUE					
100	S	52,272	14	1.00	A	1.00	A	1.00	613,760	1.10	A	1.00	PF4	2.80			813,110

TOTAL	1.200 Acres		ZONING	RM	FRNT	0	ASSESSED	CURRENT	PREVIOUS
Nbhd	NBHD 14		NOTE				LAND	813,100	767,100
St Ind	AVERAGE			BUILDING	328,300	310,300			
Infl	AVERAGE			DETACHED	3,600	3,500			
				OTHER	0	0			
							TOTAL	1,145,000	1,080,900

DETACHED

TY	QUAL	COND	DIM/NOTE		YB	UNITS	ADJ PRICE	RCNLD	
SHF	A	1.00	20	0.80	12X16	2003	192	20.77	3,200
SHF	A	1.00	10	0.90	3X7	2010	21	22.94	400



BLDG COMMENTS
 PATH TO WATER
 BMF=2 BDRM,BATH

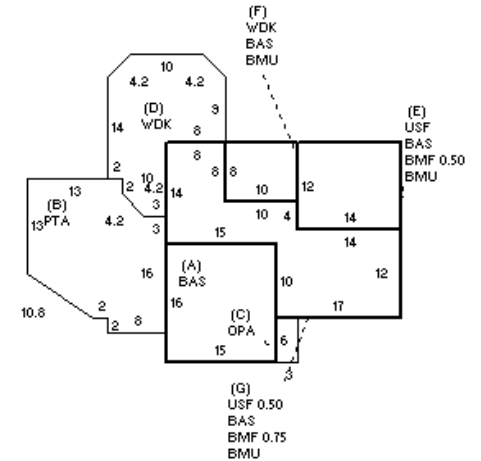

BUILDING

BUILDING	CD	ADJ	DESC	MEASURE	8/29/2017	NF
MODEL	1		RESIDENTIAL			
STYLE	8	0.95	CONTEMPOR [100%]	LIST	7/3/2018	NF
QUALITY	+	1.10	PLUS AVE [100%]	REVIEW	1/12/2021	JMG
FRAME	1	1.00	WD FRAME [100%]			

G

YEAR BLT	1979	SIZE ADJ	1.000	ELEMENT	CD	DESCRIPTION	ADJ	S	BAT	T	DESCRIPTION	UNITS	YB	ADJ PRICE	RCN	TOTAL RCN	437,797				
NET AREA	1,211	DETAIL ADJ	1.000	FOUNDATION	4	FLR & WALL	1.00	A	BAS	L	BASE AREA	240	1979	303.69	72,885	CONDITION ELEM CD					
\$NLA(RCN)	\$362	OVERALL	1.000	EXT COVER	1	WD SHINGLE	1.00	B	PTA	N	PATIO	325		14.87	4,831	EXTERIOR	A				
				ROOF SHAPE	6	SALTBOX	1.00	C	OPA	N	OPEN PORCH	18		55.00	990	INTERIOR	G				
				ROOF COVER	1	ASPH/CMP SH	1.00	+	WDK	N	WOOD DECK	329		43.12	14,187	KITCHEN	A				
				FLOOR COVER	1	HARDWOOD	1.00	+	BMU	N	BSMT UNFINISHED	618		68.53	42,354	BATHS	A				
				INT FINISH	2	DRYWALL	1.00	+	BMF	N	BSMT FINISH	362		44.37	16,061	HEAT/ELEC	A				
				HEATING/COOL	11	HTWT/CL AIR	1.05	+	USF	L	BASE AREA	618	1979	303.69	187,679						
				FUEL SOURCE	2	GAS	1.00	+	BAS	L	UPPER STORY FIN	353	1979	204.30	72,117						
													F21	O	FPL 2S 1OP	1		11,166.10	11,166		
													ODS	O	OUTDOOR SHOWER	1		2,656.50	2,657		
													EFF.YR/AGE				1983 / 40				
													COND		25 25 %						
													FUNC		0						
													ECON		0						
													DEPR		25 % GD		75				
													RCNLD				\$328,300				