

Key: 6992

Town of BREWSTER - Fiscal Year 2025

9/17/2024 2:15 pm SEQ #: 7.216

LEGALS

CURRENT OWNER		PARCEL ID		LOCATION	
KOBOLD JEFFREY J & JULIE 133 LAKE SHORE DRIVE BREWSTER, MA 02631		51-63-0		133-135 LAKE SHORE DRIVE	
TRANSFER HISTORY		DOS	T	SALE PRICE	BK-PG (Cert)
KOBOLD JEFFREY J & JULIE		04/23/2003	QS	482,000	(168945)
KENILEY CHRISTOPHER H		10/29/1999	QS	250,000	(155343)
CRANDELL KATHERINE L &		12/21/1988	XX		(116357)

CLASS	CLASS%	DESCRIPTION		BN ID	BN	CARD	
1010	100	SINGLE FAMILY			1	1 of 1	
PMT NO	PMT DT	TY	DESC	AMOUNT	INSP	BY	1st %
150	05/05/1989	1	NEW CONSTRUC		03/14/1991		100 100

LAND

CD	T	AC/SF/UN	Nbhd	St Ind	Infl	ADJ BASE	SAF	Topo	Lpi	VC	CREDIT AMT	ADJ VALUE		
100	S	60,000	14	1.00	A	1.00	A	1.00	226,872	1.00	10	0.90 R03	1.15	313,960
300	A	0.043	14	1.00	A	1.00	A	1.00	13,800	1.00	A	1.00 R03	1.15	590

TOTAL	1.420 Acres	ZONING	RL	FRNT	0	ASSESSED	CURRENT	PREVIOUS
Nbhd	NBHD 14	N O T E	T=SLOPE			LAND	314,600	322,600
St Ind	AVERAGE		LAND	560,900	536,300			
Infl	AVERAGE		DETACHED	13,500	13,400			
			OTHER	0	0			
						<b>TOTAL</b>	<b>889,000</b>	<b>872,300</b>

DETACHED

TY	QUAL	COND	DIM/NOTE	YB	UNITS	ADJ PRICE	RCNLD	PHOTO
DGF	A	1.00	10 0.90 22X24		528	28.49	13,500	09/07/2017



BLDG COMMENTS
EXTRA FIXTURE FROM BATHROOM IN GARAGE

BUILDING

BUILDING	CD	ADJ	DESC	MEASURE	9/7/2017	NF
MODEL	1		RESIDENTIAL	LIST	4/23/2007	JH
STYLE	8	0.95	CONTEMPOR [100%]	REVIEW	11/7/2017	TD
QUALITY	A	1.00	AVG [100%]			
FRAME	1	1.00	WD FRAME [100%]			

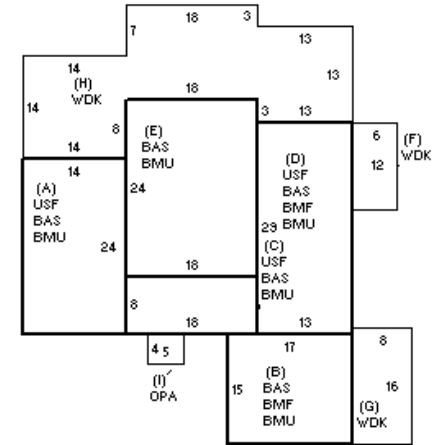

YEAR BLT	1990	SIZE ADJ	1.000	ELEMENT	CD	DESCRIPTION	ADJ	S	BAT	T	DESCRIPTION	UNITS	YB	ADJ PRICE	RCN
NET AREA	2,401	DETAIL ADJ	1.000	FOUNDATION	4	FLR & WALL	1.00	+	BMU	N	BSMT UNFINISHED	1,544		51.58	79,633
\$NLA(RCN)	\$285	OVERALL	0.980	EXT COVER	10	VERT BOARD	0.98	+	BAS	L	BASE AREA	1,112	1990	236.74	263,254
				ROOF SHAPE	1	GABLE	1.00	+	USF	L	UPPER STORY FIN	857	1990	178.33	152,831
				ROOF COVER	1	ASPH/CMP SH	1.00	+	BMF	N	BSMT FINISH	632		36.84	23,284
				FLOOR COVER	1	HARDWOOD	1.00	E	BAS	L	BASE AREA	432	1990	236.74	102,271
				INT FINISH	2	DRYWALL	1.00	+	WDK	N	WOOD DECK	799		38.42	30,695
				HEATING/COOL	11	HTWT/CL AIR	1.05	I	OPA	N	OPEN PORCH	20		49.00	980
				FUEL SOURCE	2	GAS	1.00		BMG	O	BSMT GARAGE	2		3,031.65	6,063
									F21	O	FPL 2S 1OP	1		9,948.00	9,948
									ODS	O	OUTDOOR SHOWER	1		2,366.70	2,367

TOTAL RCN	684,065
CONDITION ELEM	CD
EXTERIOR	A
INTERIOR	G
KITCHEN	G
BATHS	A
HEAT/ELEC	A
EFF.YR/AGE	1997 / 26
COND	18 18 %
FUNC	0
ECON	0
DEPR	18 % GD 82
RCNLD	\$560,900