

Key: 7161

Town of BREWSTER - Fiscal Year 2025

9/17/2024 2:15 pm SEQ #: 7.389

LEGAL

CURRENT OWNER		PARCEL ID		LOCATION	
IANNONE PETER J & IANNONE THERESA MCFADDEN 397 CROWELLS BOG ROAD BREWSTER, MA 02631		62-41-0		397 CROWELLS BOG ROAD	
TRANSFER HISTORY		DOS	T	SALE PRICE	BK-PG (Cert)
		06/30/2011	QS	1,100,000	(194645)
		09/19/1997	QS	227,500	(145868)

CLASS	CLASS%	DESCRIPTION		BN ID	BN	CARD	
1010	100	SINGLE FAMILY			1	1 of 2	
PMT NO	PMT DT	TY	DESC	AMOUNT	INSP	BY	1st %
147	03/05/2012	7	ALTERATIONS	3,800	01/18/2013	MR	100 100
3	01/03/2012	7	ALTERATIONS	40,000	01/18/2013	MR	100 100
		12	CYCLICAL NON		02/03/2004	TG	100 100
77	02/13/1998	5	OTHER	12,000	07/27/1999	JB	100 100
76	02/13/1998	1	NEW CONSTRUC	300,000	07/27/1999	JB	100 100

LAND

CD	T	AC/SF/UN	Nbhd	St Ind	Infl	ADJ BASE	SAF	Topo	Lpi	VC	CREDIT AMT	ADJ VALUE	
100	S	60,000	13	1.00	13F	1.00	A	1.00	767,200	1.00	A	1.00	1,061,720
300	A	0.703	13	1.00	13F	1.00	A	1.00	42,000	1.00	A	1.00	29,530

TOTAL	2.080 Acres	ZONING	RR	FRNT	0	ASSESSED	CURRENT	PREVIOUS
Nbhd	NBHD 13	NOTE	LAND	1,091,300	1,029,500			
St Ind	CROWELL'S BOG		BUILDING	1,169,000	1,116,800			
Infl	AVERAGE		DETACHED	3,700	3,600			
			OTHER	0	0			
			TOTAL	2,264,000	2,149,900			

DETACHED

TY	QUAL	COND	DIM/NOTE	YB	UNITS	ADJ PRICE	RCNLD
HTB	A	1.00	10 0.90	2012	1	4,058.10	3,700



BLDG COMMENTS
GAS FIREPLACE / BRICK HEARTH

BUILDING

BUILDING	CD	ADJ	DESC	MEASURE	1/5/2011	JH
MODEL	1		RESIDENTIAL	LIST	1/5/2011	JH
STYLE	4	1.02	CAPE [100%]	REVIEW	3/28/2013	MR
QUALITY	G+	1.45	GOOD + [100%]			
FRAME	1	1.00	WD FRAME [100%]			

G

YEAR BLT	1998	SIZE ADJ	0.980	ELEMENT	CD	DESCRIPTION	ADJ	S	BAT	T	DESCRIPTION *	UNITS	YB	ADJ PRICE	RCN	TOTAL RCN	1,328,433
NET AREA	3,015	DETAIL ADJ	1.000	FOUNDATION	4	FLR & WALL	1.00	+	BMU	N	BSMT UNFINISHED	2,447		68.49	167,590	CONDITION ELEM	CD
\$NLA(RCN)	\$441	OVERALL	1.050	EXT COVER	4	VINYL	1.00	A	BAS	L	BASE AREA	405	1998	331.01	134,059	EXTERIOR	G
				ROOF SHAPE	1	GABLE	1.00	+	USF	L	UPPER STORY FIN	780	1998	274.31	213,962	INTERIOR	G
				ROOF COVER	1	ASPH/CMP SH	1.00	+	BAS	L	BASE AREA	520	1998	331.01	172,126	KITCHEN	G
				FLOOR COVER	1	HARDWOOD	1.00	D	ATU	N	ATTIC UNF	145		79.68	11,553	BATHS	A
				INT FINISH	2	DRYWALL	1.00	E	ATU	N	ATTIC UNF	95		79.68	7,569	HEAT/ELEC	A
				HEATING/COOL	9	WARM/CL AIR	1.03	+	BAS	L	BASE AREA	1,310	1998	331.01	433,626		
				FUEL SOURCE	2	GAS	1.00	G	AGR	N	ATT GARAGE	220		65.60	14,431		
								G	ATU	N	ATTIC UNF	66		79.67	5,258		
								+	WDK	N	WOOD DECK	734		58.49	42,931		
								J	OPA	N	OPEN PORCH	108		74.60	8,057		
								K	AGR	N	ATT GARAGE	748		55.30	41,367		
								K	ATU	N	ATTIC UNF	224		79.68	17,848		
								O	PTA	N	PATIO	501		17.79	8,914		
								F21	O	FPL 2S 1OP	1		15,145.80	15,146			
								GFP	O	GAS FIREPLACE	1		4,664.10	4,664			

* -- Partial Listing. See Next Page.

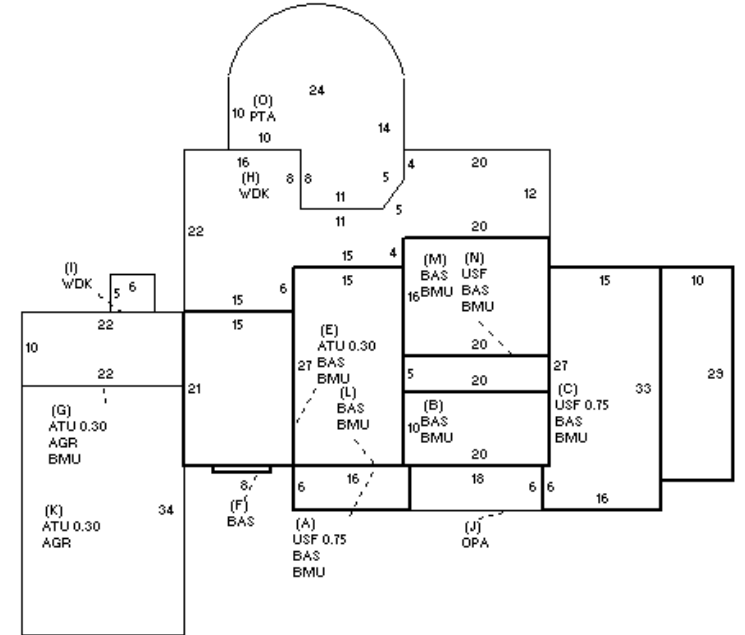

EFF.YR/AGE	2009 / 14
COND	12 12 %
FUNC	0
ECON	0
DEPR	12 % GD 88
RCNLD	\$1,169,000

Key: 7161

Town of BREWSTER - Fiscal Year 2025

9/17/2024 2:15 pm SEQ #: 7.390

LEGAL

CURRENT OWNER				PARCEL ID				LOCATION			
IANNONE PETER J & IANNONE THERESA MCFADDEN 397 CROWELLS BOG ROAD BREWSTER, MA 02631				62-41-0				397 CROWELLS BOG ROAD			
TRANSFER HISTORY				DOS	T	SALE PRICE	BK-PG (Cert)				

CLASS	CLASS%	DESCRIPTION			BN ID	BN	CARD	
1010	100	SINGLE FAMILY				1	2 of 2	
PMT NO	PMT DT	TY	DESC	AMOUNT	INSP	BY	1st	%

LAND

CD	T	AC/SF/UN	Nbhd	St Ind	Infl	ADJ BASE	SAF	Topo	Lpi	VC	CREDIT AMT	ADJ VALUE
----	---	----------	------	--------	------	----------	-----	------	-----	----	------------	-----------

* -- Partial Listing. See Previous Page.

DETACHED

TOTAL	ZONING	FRNT	ASSESSED	CURRENT	PREVIOUS
Nbhd	NOTE		LAND		
St Ind			BUILDING		
Infl			DETACHED		
			OTHER		
			TOTAL		

TY	QUAL	COND	DIM/NOTE	YB	UNITS	ADJ PRICE	RCNLD	PHOTO
----	------	------	----------	----	-------	-----------	-------	-------

BUILDING

BUILDING	CD	ADJ	DESC	MEASURE
MODEL				LIST
STYLE				REVIEW
QUALITY				
FRAME				

YEAR BLT	SIZE ADJ	ELEMENT	CD	DESCRIPTION	ADJ	S	BAT	T	DESCRIPTION *	UNITS	YB	ADJ PRICE	RCN	TOTAL RCN
NET AREA	DETAIL ADJ						ODS	O	OUTDOOR SHOWER	1		3,603.30	3,603	CONDITION ELEM
\$NLA(RCN)	OVERALL													CD
CAPACITY		UNITS	ADJ											

EFF.YR/AGE	% GD
COND	
FUNC	
ECON	
DEPR	
RCNLD	