

Key: 7255

Town of BREWSTER - Fiscal Year 2025

9/17/2024 2:15 pm SEQ #: 7.480

LEGAL

LAND

DETACHED

BUILDING

| CURRENT OWNER | | PARCEL ID | | LOCATION | |
|---|--|------------|----|-----------------------|--------------|
| ETEN JOHN L & STROUGH SYBIL J TRUSTEES THE BESSE CARTWAY NT P O BOX 507 BREWSTER, MA 02631 | | 83-6-0 | | 441 W H BESSE CARTWAY | |
| TRANSFER HISTORY | | DOS | T | SALE PRICE | BK-PG (Cert) |
| ETEN JOHN L & STROUGH SYB | | 07/24/2000 | F | 13142-066 | 1 |
| ETEN JOHN L & STROUGH SYB | | 10/29/1985 | XX | 4775-178 | |

| CLASS | CLASS% | DESCRIPTION | | BN ID | BN | CARD | |
|--------|------------|----------------|--------------|--------|------------|--------|---------|
| 0180 | 100 | Mixed-Res/Chpt | | | 1 | 1 of 1 | |
| PMT NO | PMT DT | TY | DESC | AMOUNT | INSP | BY | 1st % |
| 23-145 | 02/14/2023 | 77 | SOLAR PANELS | 50,000 | 05/24/2024 | PJK | 100 100 |
| 474 | 07/02/2012 | 1 | NEW CONSTRUC | 45,000 | 07/01/2013 | TRL | 100 100 |
| 613 | 12/03/2010 | 1 | NEW CONSTRUC | 38,000 | 07/01/2013 | TRL | 100 100 |
| NP | | 12 | CYCLICAL NON | | 04/11/2007 | JH | 100 100 |
| 391 | 12/03/1990 | 2 | ADD | 2,500 | | | 100 100 |

| CD | T | AC/SF/UN | Nbhd | St Ind | Infl | ADJ BASE | SAF | Topo | Lpi | VC | CREDIT AMT | ADJ VALUE | |
|-----|---|----------|------|--------|------|----------|-----|------|---------|------|------------|-----------|-----------|
| 100 | S | 60,000 | 13 | 1.00 | A | 1.00 | A | 1.00 | 767,200 | 1.00 | A | 1.00 | 1,061,720 |
| 300 | A | 1,500 | 13 | 1.00 | A | 1.00 | A | 1.00 | 42,000 | 1.00 | A | 1.00 | 2,040 |
| 300 | A | 5,143 | 13 | 1.00 | A | 1.00 | A | 1.00 | 42,000 | 1.00 | A | 1.00 | 54,000 |

| | | | | | | | | |
|--------|-------------|--------|----------|-----------|-----------|----------|---------|----------|
| TOTAL | 8.019 Acres | ZONING | RR | FRNT | 0 | ASSESSED | CURRENT | PREVIOUS |
| Nbhd | NBHD 13 | NOTE | LAND | 1,117,760 | 1,054,390 | | | |
| St Ind | AVERAGE | | BUILDING | 818,200 | 782,400 | | | |
| Infl | AVERAGE | | DETACHED | 105,400 | 104,400 | | | |
| | | | OTHER | 0 | 0 | | | |
| | | | TOTAL | 2,041,360 | 1,941,190 | | | |

| TY | QUAL | COND | DIM/NOTE | YB | UNITS | ADJ PRICE | RCNLD |
|-----|------|------|----------|--------------|-------|-----------|--------|
| CTA | A | 1.00 | 10 0.90 | | 1 | 36,296.90 | 32,700 |
| IPG | A | 1.00 | 10 0.90 | | 800 | 45.42 | 32,700 |
| CTT | A | 1.00 | NV 0.00 | EX-WIND TURB | 2013 | 1,002.30 | |
| FBN | V | 1.50 | 10 0.90 | 30X40 | 2012 | 37.05 | 40,000 |

PHOTO 12/15/2010

BLDG COMMENTS
WALK-OUT BASEMENT - WATERFRONT

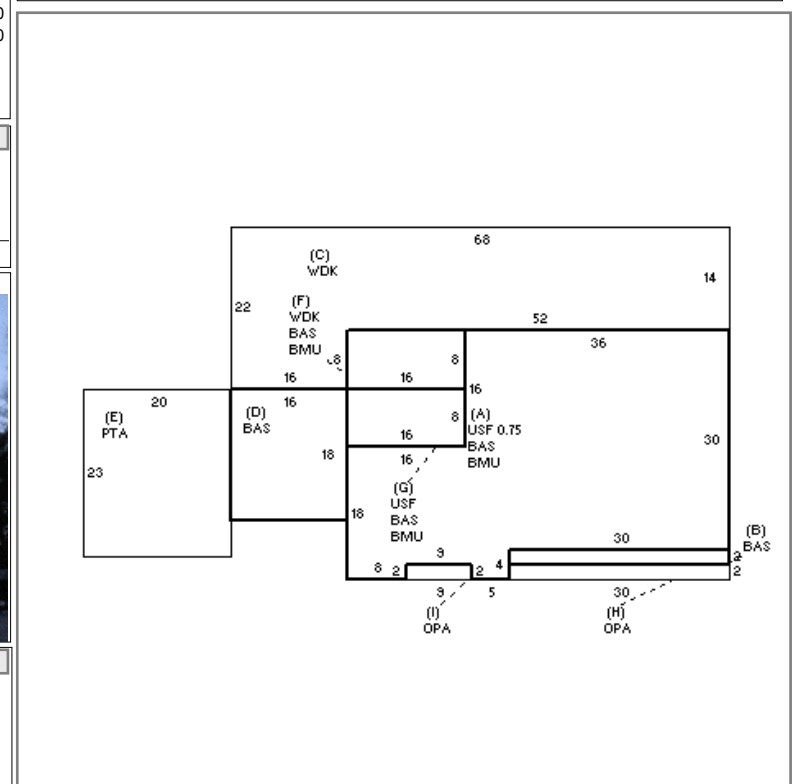

| BUILDING | CD | ADJ | DESC | MEASURE | 4/11/2007 | JH |
|----------|----|------|-----------------|---------|-----------|-----|
| MODEL | 1 | | RESIDENTIAL | LIST | 4/11/2007 | EST |
| STYLE | 4 | 1.02 | CAPE [100%] | REVIEW | 1/24/2011 | JH |
| QUALITY | G | 1.30 | GOOD [100%] | | | |
| FRAME | 1 | 1.00 | WD FRAME [100%] | | | |

| YEAR BLT | 1988 | SIZE ADJ | 0.980 | ELEMENT | CD | DESCRIPTION | ADJ | S | BAT | T | DESCRIPTION | UNITS | YB | ADJ PRICE | RCN | TOTAL RCN | 1,062,631 |
|------------|-------|------------|-------|--------------|----|-------------|------|---|-----|---|-----------------|-------|------|-----------|---------|----------------|------------|
| NET AREA | 3,137 | DETAIL ADJ | 1.000 | FOUNDATION | 4 | FLR & WALL | 1.00 | + | BMU | N | BSMT UNFINISHED | 1,630 | | 66.47 | 108,349 | | |
| \$NLA(RCN) | \$339 | OVERALL | 1.020 | EXT COVER | 4 | VINYL | 1.00 | + | USF | L | UPPER STORY FIN | 1,159 | 1988 | 229.16 | 265,592 | | |
| | | | | ROOF SHAPE | 1 | GABLE | 1.00 | + | BAS | L | BASE AREA | 1,978 | 1988 | 294.70 | 582,909 | | |
| | | | | ROOF COVER | 1 | ASP/CMP SH | 1.00 | + | WDK | N | WOOD DECK | 1,208 | | 50.94 | 61,536 | | |
| | | | | FLOOR COVER | 1 | HARDWOOD | 1.00 | E | PTA | N | PATIO | 460 | | 16.53 | 7,603 | | |
| | | | | INT FINISH | 2 | DRYWALL | 1.00 | + | OPA | N | OPEN PORCH | 78 | | 64.97 | 5,088 | | |
| | | | | HEATING/COOL | 2 | HOT WATER | 1.00 | | BMG | O | BSMT GARAGE | 2 | | 4,019.95 | 8,040 | | |
| | | | | FUEL SOURCE | 1 | OIL | 1.00 | | F21 | O | FPL 2S 1OP | 1 | | 13,191.00 | 13,191 | | |
| | | | | | | | | | | | | | | | | CONDITION ELEM | CD |
| | | | | | | | | | | | | | | | | EXTERIOR | A |
| | | | | | | | | | | | | | | | | INTERIOR | A |
| | | | | | | | | | | | | | | | | KITCHEN | A |
| | | | | | | | | | | | | | | | | BATHS | A |
| | | | | | | | | | | | | | | | | HEAT/ELEC | A |
| | | | | | | | | | | | | | | | | EFF.YR/AGE | 1988 / 35 |
| | | | | | | | | | | | | | | | | COND | 23 23 % |
| | | | | | | | | | | | | | | | | FUNC | 0 |
| | | | | | | | | | | | | | | | | ECON | 0 |
| | | | | | | | | | | | | | | | | DEPR | 23 % GD 77 |
| | | | | | | | | | | | | | | | | RCNLD | \$818,200 |