

Key: 7391

Town of BREWSTER - Fiscal Year 2025

9/17/2024 2:15 pm SEQ #: 7.621

LEGALS

CURRENT OWNER				PARCEL ID				LOCATION			
MURPHY VERE E TRUSTEE THE VERE E MURPHY 2016 LIVING TRUST PO BOX 2215 ORLEANS, MA 02653				63-28-0				204 GULLS WAY			
TRANSFER HISTORY				DOS	T	SALE PRICE	BK-PG (Cert)				
MURPHY VERE E TRUSTEE				11/30/2016	F	1	30194-76				
MURPHY VERE E				05/07/2012	A	200,000	26310-277				
MURPHY PETER B				12/19/1972	XX		1781-271				

CLASS	CLASS%	DESCRIPTION			BN ID	BN	CARD	
1010	100	SINGLE FAMILY				1	1 of 1	
PMT NO	PMT DT	TY	DESC	AMOUNT	INSP	BY	1st	%
240	03/18/2019	7	ALTERATIONS	4,829	07/14/2020	TCK	100	100
923	10/11/2016	3	OUT BUILDING	2,500	03/13/2017	NF	100	100
123	03/10/2015	77	SOLAR PANELS	13,000	05/12/2016	WFF	100	100
NP		12	CYCLICAL NON		04/06/2007	JH	100	100

LAND

CD	T	AC/SF/UN	Nbhd	St Ind	Infl	ADJ BASE	SAF	Topo	Lpi	VC	CREDIT AMT	ADJ VALUE					
100	S	30,000	13	1.00	A	1.00	A	1.00	767,200	1.62	A	1.00	PF4	3.50			853,590

DETACHED

TOTAL	30,000 SF	ZONING	RR	FRNT	0	ASSESSED	CURRENT	PREVIOUS
Nbhd	NBHD 13	NOTE	LAND	853,600	805,300			
St Ind	AVERAGE		BUILDING	406,200	388,700			
Infl	AVERAGE		DETACHED	1,600	1,600			
			OTHER	0	0			
TOTAL				1,261,400	1,195,600			

TY	QUAL	COND	DIM/NOTE	YB	UNITS	ADJ PRICE	RCNLD	PHOTO	07/14/2020
SHF	A	1.00	10 0.90 10X8	2016	80	22.01	1,600		

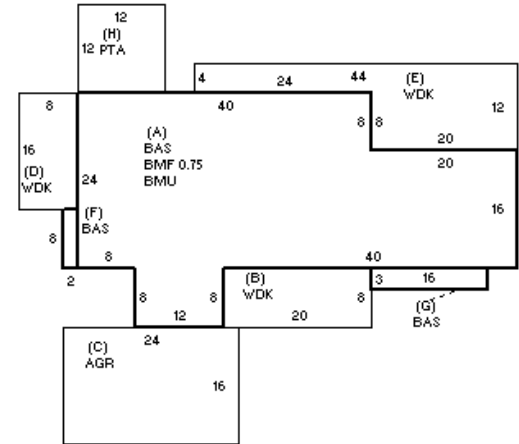

BUILDING

BUILDING	CD	ADJ	DESC	MEASURE	4/6/2007	JH	BLDG COMMENTS
MODEL	1		RESIDENTIAL	LIST	4/6/2007	EST	SOLAR PANELS
STYLE	1	1.00	RANCH [100%]	REVIEW	7/31/2020	ER	
QUALITY	+	1.10	PLUS AVE [100%]				
FRAME	1	1.00	WD FRAME [100%]				

YEAR BLT	1984	SIZE ADJ	1.000	ELEMENT	CD	DESCRIPTION	ADJ	S	BAT	T	DESCRIPTION	UNITS	YB	ADJ PRICE	RCN	TOTAL RCN	541,604
NET AREA	1,440	DETAIL ADJ	1.000	FOUNDATION	4	FLR & WALL	1.00	A	BMU	N	BSMT UNFINISHED	1,376		56.78	78,135		
\$NLA(RCN)	\$376	OVERALL	0.950	EXT COVER	2	CLAPBOARD	1.00	A	BMF	N	BSMT FINISH	1,032		35.60	36,741		
				ROOF SHAPE	1	GABLE	1.00	+	WDK	N	WOOD DECK	624		40.96	25,562		
				ROOF COVER	1	ASPH/CMP SH	1.00	C	AGR	N	ATT GARAGE	384		43.24	16,603		
				FLOOR COVER	2	SOFTWOOD	1.00	+	BAS	L	BASE AREA	1,440	1984	252.44	363,515		
				INT FINISH	2	DRYWALL	1.00	H	PTA	N	PATIO	144		16.62	2,393		
				HEATING/COOL	5	ELECTRIC BB	1.00	F11	O	FPL 1S 1OP	1		7,980.70	7,981			
				FUEL SOURCE	3	ELECTRIC	0.95	ODS	O	OUTDOOR SHOWER	1		2,523.70	2,524			

CONDITION ELEM	CD
EXTERIOR	A
INTERIOR	A
KITCHEN	A
BATHS	A
HEAT/ELEC	A

EFF. YR/AGE	1984 / 39
COND	25 25 %
FUNC	0
ECON	0
DEPR	25 % GD 75
RCNLD	\$406,200