

Key: 74

Town of BREWSTER - Fiscal Year 2025

9/17/2024 2:15 pm SEQ #: 79

LEGALS

CURRENT OWNER				PARCEL ID				LOCATION			
32 CEDAR HILL LLC 2231 PACIFIC DRIVE CORONA DEL MAR, CA 92625				38-36-0				32 CEDAR HILL ROAD			
TRANSFER HISTORY				DOS	T	SALE PRICE	BK-PG (Cert)				
32 CEDAR HILL LLC				03/17/2000	F	12887-154	1				
MOSES PAUL A & LUBASH BAR				01/20/1999	A	175,000	12004-110				
MOSES PAUL A & VISSER DEB				01/20/1999	A	12004-108	1				

CLASS	CLASS%	DESCRIPTION			BN ID	BN	CARD	
1010	100	SINGLE FAMILY				1	1 of 1	
PMT NO	PMT DT	TY	DESC	AMOUNT	INSP	BY	1st	%
172	03/03/2020	7	ALTERATIONS	7,500	12/11/2020	NF	100	100
345	04/25/2013	1	NEW CONSTRUC		08/06/2014	RJM	100	100
644	04/25/2013	2	ADD	75,000	08/06/2014	RJM	100	100
642	10/05/2007	7	ALTERATIONS	14,000	03/09/2009	JH	100	100
		7	ALTERATIONS	4,500	07/19/2008	DHT	100	100

LAND

CD	T	AC/SF/UN	Nbhd	St Ind	Infl	ADJ BASE	SAF	Topo	Lpi	VC	CREDIT AMT	ADJ VALUE
100	S	17,200	1	1.00	A	1,139,840	2.51	A	1.00	BGD	5.20	1,128,740

TOTAL	17,200 SF	ZONING	RM	FRNT	0	ASSESSED	CURRENT	PREVIOUS
Nbhd	NBHD 1	NOTE				LAND	1,128,700	1,064,900
St Ind	AVERAGE		BUILDING	461,300	435,500			
Infl	AVERAGE		DETACHED	0	0			
			OTHER	0	0			
						<b>TOTAL</b>	<b>1,590,000</b>	<b>1,500,400</b>

DETACHED

TY	QUAL	COND	DIM/NOTE	YB	UNITS	ADJ PRICE	RCNLD	PHOTO
								12/11/2020

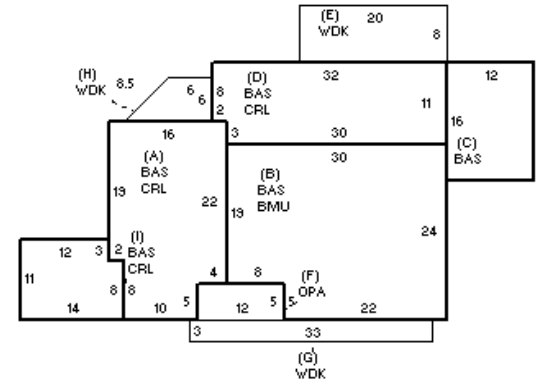

BUILDING

BUILDING	CD	ADJ	DESC	MEASURE	3/16/2018	NF
MODEL	1		RESIDENTIAL	LIST	3/16/2018	EST
STYLE	6	1.05	COTT/BUNGLW [100%]	REVIEW	1/20/2021	MR
QUALITY	A+	1.20	AVG + [100%]			
FRAME	1	1.00	WD FRAME [100%]			

BLDG COMMENTS

LOADING

YEAR BLT	1966	SIZE ADJ	1.000	ELEMENT	CD	DESCRIPTION	ADJ	S	BAT	T	DESCRIPTION	UNITS	YB	ADJ PRICE	RCN	TOTAL RCN	623,368
NET AREA	1,762	DETAIL ADJ	1.000	FOUNDATION	4	FLR & WALL	1.00	A	CRL	N	BSMT CRAWL	396		36.44	14,429	CONDITION ELEM	CD
\$NLA(RCN)	\$354	OVERALL	1.000	EXT COVER	1	WD SHINGLE	1.00	A	BAS	L	BASE AREA	396	1999	283.97	112,451	EXTERIOR	G
				ROOF SHAPE	1	GABLE	1.00	B	BMU	N	BSMT UNFINISHED	680		74.77	50,840	INTERIOR	A
				ROOF COVER	1	ASPH/CMP SH	1.00	+	BAS	L	BASE AREA	1,218	1966	283.97	345,874	KITCHEN	A
				FLOOR COVER	5	VINYL	1.00	D	CRL	N	BSMT CRAWL	346		36.44	12,607	BATHS	A
				INT FINISH	5	MIN/OTHER	0.95	+	WDK	N	WOOD DECK	313		47.04	14,724	HEAT/ELEC	A
				HEATING/COOL	2	HOT WATER	1.00	F	OPA	N	OPEN PORCH	60		60.00	3,600		
				FUEL SOURCE	2	GAS	1.00	I	CRL	N	BSMT CRAWL	148		36.44	5,393		
								I	BAS	L	BASE AREA	148	2013	283.97	42,028		
								F11	O	FPL 1S IOP	1		9,164.40	9,164			
								ODS	O	OUTDOOR SHOWER	1		2,898.00	2,898			
												EFF.YR/AGE	1981 / 42				
												COND	26 26 %				
												FUNC	0				
												ECON	0				
												DEPR	26 % GD		74		
												RCNLD			\$461,300		