

Key: 7496

Town of BREWSTER - Fiscal Year 2025

9/17/2024 2:15 pm SEQ #: 7.726

LEG  
A  
L  
L  
A  
N  
D

CURRENT OWNER				PARCEL ID				LOCATION				
FERNANDES KEITH E & ABIGAIL L 22 SHEFFIELD ROAD BREWSTER, MA 02631				95-80-0				22 SHEFFIELD ROAD				
TRANSFER HISTORY				DOS	T	SALE PRICE	BK-PG (Cert)					
FERNANDES KEITH E & ABIGA				06/01/2012	H	285,000	26383-185					
SOMERVILLE WARREN R &				09/11/2002	F	1 15582-350						
SOMERVILLE WARREN R &				03/01/2002	F	1 14875-189						
CD	T	AC/SF/UN	Nbhd	St Ind	Infl	ADJ BASE	SAF	Topo	Lpi	VC	CREDIT AMT	ADJ VALUE
100	S	24,294	13	1.00	A	219,200	1.90	A	1.00	R03	1.00	231,690

CLASS	CLASS%	DESCRIPTION			BN ID	BN	CARD	
1010	100	SINGLE FAMILY				1	1 of 1	
PMT NO	PMT DT	TY	DESC	AMOUNT	INSP	BY	1st	%
SR23-24	05/29/2023	3	OUT BUILDING	2,500	05/17/2024	TCK	0	0
171	02/16/2022	7	ALTERATIONS	15,000	04/20/2022	TCK	100	100
559	08/27/2020	10	INGROUND POO	45,000	04/20/2022	TCK	100	100
779	09/04/2019	2	ADD	8,000	11/16/2020	TCK	100	100
649	07/15/2019	3	OUT BUILDING	1,000	07/06/2020	TCK	100	100

DE  
T  
A  
C  
H  
E  
D

TOTAL	24,294 SF	ZONING	RM	FRNT	0	ASSESSED	CURRENT	PREVIOUS
Nbhd	NBHD 13	N O T E				LAND	231,700	218,600
St Ind	AVERAGE					BUILDING	548,700	524,400
Infl	AVERAGE					DETACHED	29,700	29,500
						OTHER	0	0
						TOTAL	810,100	772,500

TY	QUAL	COND	DIM/NOTE	YB	UNITS	ADJ PRICE	RCNLD
PTD	A	1.00	10 0.90 14X26	2010	364	7.65	2,500
DDK	A	1.00	10 0.90 14X14	2010	196	12.50	2,200
DDK	A	1.00	10 0.90 14X14	2010	196	12.50	2,200
SHF	A	1.00	01 1.00 7X12	2019	84	22.01	1,800
IPV	A	1.00	01 1.00 18X36	2020	648	32.47	21,000

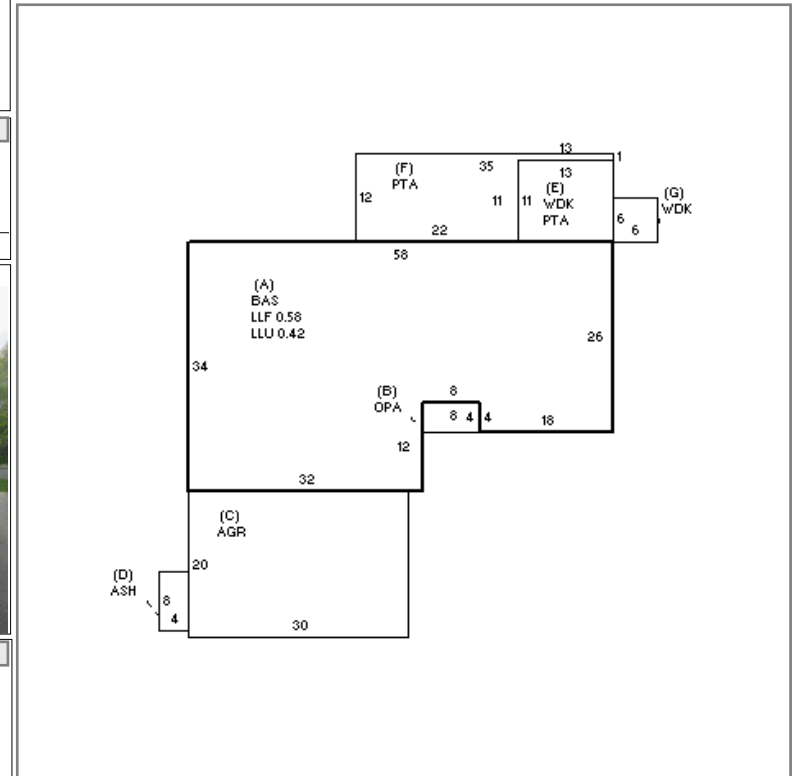

B  
U  
I  
L  
D  
I  
N  
G

BUILDING	CD	ADJ	DESC	MEASURE	11/16/2020	TCK
MODEL	1		RESIDENTIAL	LIST	1/21/2011	JH
STYLE	1	1.00	RANCH [100%]	REVIEW	6/5/2024	EMZ
QUALITY	A	1.00	AVG [100%]			
FRAME	1	1.00	WD FRAME [100%]			

BLDG COMMENTS

YEAR BLT	1986	SIZE ADJ	0.990	ELEMENT	CD	DESCRIPTION	ADJ	S	BAT	T	DESCRIPTION	UNITS	YB	ADJ PRICE	RCN	TOTAL RCN	669,127
NET AREA	2,737	DETAIL ADJ	1.000	FOUNDATION	4	FLR & WALL	1.00	A	LLU	N	LOWER LEVEL UNF	727		87.94	63,931		
\$NLA(RCN)	\$244	OVERALL	1.030	EXT COVER	1	WD SHINGLE	1.00	A	LLF	L	LOWER LEVEL FIN	1,005	1986	125.03	125,657		
				ROOF SHAPE	1	GABLE	1.00	A	BAS	L	BASE AREA	1,732	1986	241.30	417,934		
				ROOF COVER	1	ASPH/CMP SH	1.00	B	OPA	N	OPEN PORCH	32		50.98	1,632		
				FLOOR COVER	3	W/W CARPET	1.00	C	AGR	N	ATT GARAGE	600		38.68	23,205		
				INT FINISH	2	DRYWALL	1.00	D	ASH	N	ATT SHED	32		29.73	951		
				HEATING/COOL	9	WARM/CL AIR	1.03	E	PTA	N	PATIO	143		16.22	2,319		
				FUEL SOURCE	2	GAS	1.00	+	WDK	N	WOOD DECK	179		39.97	7,155		
								F	PTA	N	PATIO	277		14.59	4,042		
								F11	O	FPL 1S 1OP	1		7,787.40	7,787			
								ODS	O	OUTDOOR SHOWER	1		2,462.60	2,463			
																EFF.YR/AGE	1997 / 26
																COND	18 18 %
																FUNC	0
																ECON	0
																DEPR	18 % GD 82
																RCNLD	\$548,700