

Key: 7509

Town of BREWSTER - Fiscal Year 2025

9/17/2024 2:15 pm SEQ #: 7.736

LEGALS

CURRENT OWNER		PARCEL ID		LOCATION	
ARMS JONATHAN F TRUSTEE		83-57-0		125 SCARBOROUGH ROAD	
JONATHAN F ARMS NOMINEE TRUST		TRANSFER HISTORY		DOS	T SALE PRICE BK-PG (Cert)
125 SCARBOROUGH ROAD		ARMS JONATHAN F TRUSTEE		04/05/2002	F 1 (164803)
BREWSTER, MA 02631		ARMS JONATHAN F		03/22/2002	F 1 (164643)
		ARMS JONATHAN F TRUSTEE		06/10/1996	F 100 (140972)

CLASS	CLASS%	DESCRIPTION		BN ID	BN	CARD	
1010	100	SINGLE FAMILY			1	1 of 2	
PMT NO	PMT DT	TY	DESC	AMOUNT	INSP	BY	1st %
NP		12	CYCLICAL NON		02/03/2021	TCK	100 100
676		12	CYCLICAL NON		02/25/2013	SF	100 100
246	11/04/2003	1	NEW CONSTRUC	70,000	07/22/2004	WH	100 100
628	05/18/1995	5	OTHER	1,000	05/20/1996	JB	100 100
	10/18/1994	5	OTHER	7,000	05/20/1996	JB	100 100

LAND

CD	T	AC/SF/UN	Nbhd	St Ind	Infl	ADJ BASE	SAF	Topo	Lpi	VC	CREDIT AMT	ADJ VALUE				
100	S	60,000	13	1.00	A	1.00	A	1.00	219,200	1.00	A	1.00	R03	1.00		303,350
300	A	6,913	13	1.00	A	1.00	A	1.00	12,000	1.00	A	1.00	R03	1.00		82,960

TOTAL	8.290 Acres	ZONING	RM	FRNT	0	ASSESSED	CURRENT	PREVIOUS
Nbhd	NBHD 13	NOTE				LAND	386,300	364,300
St Ind	AVERAGE		BUILDING	890,700	851,700			
Infl	AVERAGE		DETACHED	4,300	4,200			
			OTHER	142,400	134,500			
						TOTAL	1,423,700	1,354,700

DETACHED

TY	QUAL	COND	DIM/NOTE	YB	UNITS	ADJ PRICE	RCNLD
SHF	A	1.00	10 0.90 12X20		240	19.84	4,300

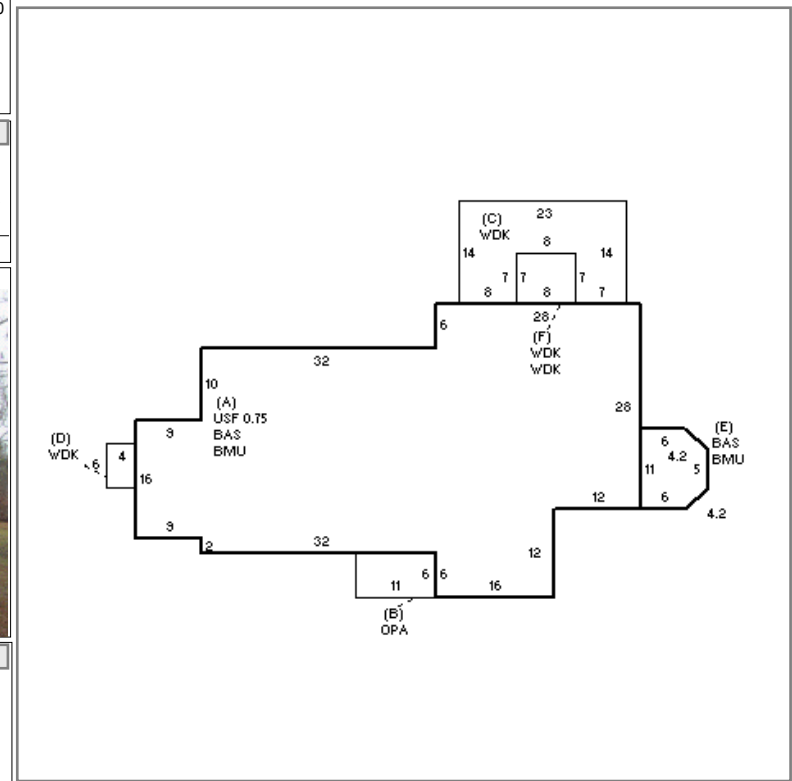

BUILDING

BUILDING	CD	ADJ	DESC	MEASURE	2/3/2021	TCK
MODEL	1		RESIDENTIAL	LIST	2/3/2021	EST
STYLE	4	1.02	CAPE [100%]	REVIEW	3/10/2021	MR
QUALITY	G	1.30	GOOD [100%]			
FRAME	1	1.00	WD FRAME [100%]			

BLDG COMMENTS

BUILDING

YEAR BLT	1994	SIZE ADJ	0.970	ELEMENT	CD	DESCRIPTION	ADJ	S	BAT	T	DESCRIPTION	UNITS	YB	ADJ PRICE	RCN	TOTAL RCN	1,113,423
NET AREA	3,618	DETAIL ADJ	1.000	FOUNDATION	4	FLR & WALL	1.00	+	BMU	N	BSMT UNFINISHED	2,106		61.32	129,133		
\$NLA(RCN)	\$308	OVERALL	1.020	EXT COVER	2	CLAPBOARD	1.00	+	BAS	L	BASE AREA	2,106	1994	285.35	600,943		
				ROOF SHAPE	1	GABLE	1.00	A	USF	L	UPPER STORY FIN	1,512	1994	207.51	313,761		
				ROOF COVER	1	ASPH/CMP SH	1.00	B	OPA	N	OPEN PORCH	66		64.31	4,245		
				FLOOR COVER	1	HARDWOOD	1.00	+	WDK	N	WOOD DECK	402		50.42	20,268		
				INT FINISH	2	DRYWALL	1.00	F21	O	O	FPL 2S 1OP	2		13,056.40	26,113		
				HEATING/COOL	2	HOT WATER	1.00										
				FUEL SOURCE	1	OIL	1.00										
																CONDITION ELEM	CD
																EXTERIOR	A
																INTERIOR	A
																KITCHEN	A
																BATHS	A
																HEAT/ELEC	A
																EFF.YR/AGE	1994 / 29
																COND	20 20 %
																FUNC	0
																ECON	0
																DEPR	20 % GD 80
																RCNLD	\$890,700

