

Key: 7680

Town of BREWSTER - Fiscal Year 2025

9/17/2024 2:15 pm SEQ #: 7.907

LEGALS

CURRENT OWNER		PARCEL ID		LOCATION	
BARKER RICHARD & JOAN 378 THOUSAND OAKS DRIVE BREWSTER, MA 02631		97-119-0		378 THOUSAND OAKS DRIVE	
TRANSFER HISTORY		DOS	T	SALE PRICE	BK-PG (Cert)
BARKER RICHARD & JOAN		01/06/1984	XX	18,000	(95008)

CLASS	CLASS%	DESCRIPTION		BN ID	BN	CARD	
1010	100	SINGLE FAMILY			1	1 of 1	
PMT NO	PMT DT	TY	DESC	AMOUNT	INSP	BY	1st %
443	05/28/2013	7	ALTERATIONS	26,000	08/19/2014	RJM	100 100
		12	CYCLICAL NON		05/09/2013	SF	100 100
297	10/15/1991	2	ADD	550	04/01/1992		100 100
268	09/23/1991	2	ADD	450			100 100
181	06/12/1990	2	ADD	15,000	03/14/1991		100 100

LAND

CD	T	AC/SF/UN	Nbhd	St Ind	Infl	ADJ BASE	SAF	Topo	Lpi	VC	CREDIT AMT	ADJ VALUE	
100	S	60,000	13	1.00	A	1.00	A	1.00	219,200	1.00	A	1.00	303,350
300	A	0.123	13	1.00	A	1.00	A	1.00	12,000	1.00	A	1.00	1,480

TOTAL	1.500 Acres	ZONING	RL	FRNT	0	ASSESSED	CURRENT	PREVIOUS
Nbhd	NBHD 13	NOTE				LAND	304,800	287,600
St Ind	AVERAGE		LAND	427,500	408,900			
Infl	AVERAGE		DETACHED	4,800	4,800			
			OTHER	0	0			
						TOTAL	737,100	701,300

DETACHED

TY	QUAL	COND	DIM/NOTE	YB	UNITS	ADJ PRICE	RCNLD
OPA	A	1.00	50 0.50	12X16	192	16.75	1,600
HTB	A	1.00	20 0.80		1	4,058.10	3,200

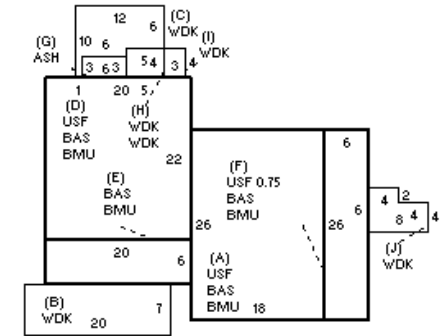

BUILDING

BUILDING	CD	ADJ	DESC	MEASURE	11/4/2020	TCK
MODEL	1		RESIDENTIAL	LIST	11/4/2020	EST
STYLE	5	1.05	COLONIAL [100%]	REVIEW	12/22/2020	MR
QUALITY	A	1.00	AVG [100%]			
FRAME	1	1.00	WD FRAME [100%]			

BLDG COMMENTS
30 SOLAR PANELS
INFO @ DOOR 11/4/20

G

YEAR BLT	1984	SIZE ADJ	1.000	ELEMENT	CD	DESCRIPTION	ADJ	S	BAT	T	DESCRIPTION	UNITS	YB	ADJ PRICE	RCN	TOTAL RCN	569,966		
NET AREA	2,209	DETAIL ADJ	1.000	FOUNDATION	4	FLR & WALL	1.00	+	BMU	N	BSMT UNFINISHED	1,184		56.46	66,852	CONDITION ELEM	CD		
\$NLA(RCN)	\$258	OVERALL	1.000	EXT COVER	1	WD SHINGLE	1.00	+	BAS	L	BASE AREA	1,184	1984	253.90	300,612	EXTERIOR	A		
				ROOF SHAPE	6	SALTBOX	1.00	+	USF	L	UPPER STORY FIN	1,025	1984	176.34	180,753	INTERIOR	A		
				ROOF COVER	1	ASPH/CMP SH	1.00	+	WDK	N	WOOD DECK	314		39.20	12,309	KITCHEN	A		
				FLOOR COVER	2	SOFTWOOD	1.00	G	ASH	N	ATT SHED	18		29.17	525	BATHS	A		
				INT FINISH	2	DRYWALL	1.00		ODS	O	OUTDOOR SHOWER	1		2,415.00	2,415	HEAT/ELEC	A		
				HEATING/COOL	5	ELECTRIC BB	1.00												
				FUEL SOURCE	3	ELECTRIC	0.95												
																		EFF.YR/AGE	1984 / 39
																		COND	25 25 %
																		FUNC	0
																		ECON	0
																		DEPR	25 % GD 75
																		RCNLD	\$427,500