

Key: 7709

Town of BREWSTER - Fiscal Year 2025

9/17/2024 2:15 pm SEQ #: 7.937

LEG
AL
LAND

CURRENT OWNER		PARCEL ID		LOCATION	
PETERSON GARRAN J & CHRISTINE J P O BOX 912 BREWSTER, MA 02631		96-89-0		67 QUASONS PATH	
TRANSFER HISTORY		DOS	T	SALE PRICE	BK-PG (Cert)
PETERSON GARRAN J & CHRIS		07/02/2018	QS	609,000	(216645)
CONLIN EDWARD J & CAROL A		02/24/1998	F	1	(147551)
CONLIN EDWARD J		06/05/1997	QS	34,000	(144686)

CLASS	CLASS%	DESCRIPTION			BN ID	BN	CARD	
1010	100	SINGLE FAMILY				1	1 of 1	
PMT NO	PMT DT	TY	DESC	AMOUNT	INSP	BY	1st	%
	07/02/2018	16	MLS REVIEW	609,000	05/02/2019	JMG	100	100
285	04/30/2015	7	ALTERATIONS	62,000	04/19/2016	WFF	100	100
983	11/26/2014	7	ALTERATIONS	1,160	06/11/2015	MW	100	100
144	03/24/2003	3	OUT BUILDING	3,000	03/21/2007	JH	100	100
460	07/30/2001	2	ADD	41,000	06/06/2002	LB	100	100

CD	T	AC/SF/UN	Nbhd	St Ind	Infl	ADJ BASE	SAF	Topo	Lpi	VC	CREDIT AMT	ADJ VALUE
100	S	25,010	13	1.00	A	1.00	A	1.00				233,360

TOTAL	25,010 SF	ZONING	RL	FRNT	0	ASSESSED	CURRENT	PREVIOUS
Nbhd	NBHD 13	NOTE	LAND	233,400	220,200			
St Ind	AVERAGE		BUILDING	720,500	680,300			
Infl	AVERAGE		DETACHED	3,600	3,500			
			OTHER	0	0			
TOTAL			TOTAL	957,500	904,000			

TY	QUAL	COND	DIM/NOTE	YB	UNITS	ADJ PRICE	RCNLD
SHF	G	1.20	10 0.90 10X16	2003	160	24.92	3,600

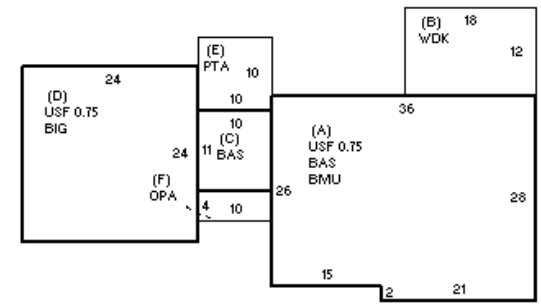

BUILDING	CD	ADJ	DESC	MEASURE	10/23/2020	TCK
MODEL	1		RESIDENTIAL	LIST	10/23/2020	EST
STYLE	4	1.02	CAPE [100%]	REVIEW	12/11/2020	MR
QUALITY	A+	1.20	AVG + [100%]			
FRAME	1	1.00	WD FRAME [100%]			

BLDG COMMENTS
INFO @ DOOR 10/23/20

DETACHED

BUILDING

YEAR BLT	1997	SIZE ADJ	1.000	ELEMENT	CD	DESCRIPTION	ADJ	S	BAT	T	DESCRIPTION	UNITS	YB	ADJ PRICE	RCN	TOTAL RCN	750,474
NET AREA	2,254	DETAIL ADJ	1.000	FOUNDATION	4	FLR & WALL	1.00	A	BMU	N	BSMT UNFINISHED	978		72.92	71,320	CONDITION ELEM	CD
\$NLA(RCN)	\$333	OVERALL	1.030	EXT COVER	1	WD SHINGLE	1.00	+	USF	L	UPPER STORY FIN	1,166	1997	217.96	254,143	EXTERIOR	V
CAPACITY			UNITS	ADJ	ROOF SHAPE	1	GABLE	1.00	B	WDK	N	WOOD DECK		48.45	10,465	INTERIOR	G
STORIES	1.75	1.00	ROOF COVER	1	ASPH/CMP SH	1.00	+	BAS	L	BASE AREA	1,088	1997	322.95	351,375	KITCHEN	V	
ROOMS	7	1.00	FLOOR COVER	1	HARDWOOD	1.00	D	BIG	N	BUILT-IN GARAGE	576		60.15	34,645	BATHS	V	
BEDROOMS	3	1.00	INT FINISH	2	DRYWALL	1.00	E	PTA	N	PATIO	100		22.61	2,261	HEAT/ELEC	A	
BATHROOMS	2	1.00	HEATING/COOL	15	HTWT+DCTLS AC	1.01	F	OPA	N	OPEN PORCH	40		61.80	2,472			
FIXTURES	7	\$11,248	FUEL SOURCE	1	OIL	1.00		F21	O	FPL 2S 1OP	1		12,546.60	12,547			
GARAGE SPACES	2	1.00															
% BSMT FIN	0	1.00															
# 1/2 BATHS	0	1.00															
# OF UNITS	0	1.00															
																EFF.YR/AGE	2019 / 4
																COND	4 4 %
																FUNC	0
																ECON	0
																DEPR	4 % GD 96
																RCNLD	\$720,500