

Key: 7739

Town of BREWSTER - Fiscal Year 2025

9/17/2024 2:15 pm SEQ #: 7.967

LEG  
AL

CURRENT OWNER				PARCEL ID				LOCATION				
BULLARD STANLEY H P O BOX 103 ORLEANS, MA 02653				95-22-0				113 JONATHANS WAY				
TRANSFER HISTORY				DOS	T	SALE PRICE		BK-PG (Cert)				
BULLARD STANLEY H				11/12/2004	QS	307,500		19238-158				
RICHARDS BART A				01/09/2002	QS	175,000		14680-090				
RICHMAN ERIK				10/31/2000	QS	173,400		13331-283				
CD	T	AC/SF/UN	Nbhd	St Ind	Infl	ADJ BASE	SAF	Topo	Lpi	VC	CREDIT AMT	ADJ VALUE
100	S	21,800	13	1.00	A	1.00	A	1.00				226,420

LAND

TOTAL	21,800 SF	ZONING	RM	FRNT	0	ASSESSED	CURRENT	PREVIOUS
Nbhd	NBHD 13	NOTE				LAND	226,400	213,600
St Ind	AVERAGE		BUILDING	287,900	271,900			
Infl	AVERAGE		DETACHED	0	0			
			OTHER	0	0			
						<b>TOTAL</b>	<b>514,300</b>	<b>485,500</b>

DET  
ACHED

TY	QUAL	COND	DIM/NOTE	YB	UNITS	ADJ PRICE	RCNLD



CLASS	CLASS%	DESCRIPTION			BN ID	BN	CARD	
1010	100	SINGLE FAMILY				1	1 of 1	
PMT NO	PMT DT	TY	DESC	AMOUNT	INSP	BY	1st	%
606	09/07/2006	7	ALTERATIONS	500	08/10/2007	JH	100	100
622	10/16/2003	2	ADD	1,300	06/11/2004	WH	100	100
		12	CYCLICAL NON		08/19/2003	JB	100	100

B  
U  
I  
L  
D  
I  
N  
G

BUILDING	CD	ADJ	DESC	MEASURE	10/29/2020	TCK
MODEL	1		RESIDENTIAL	LIST	9/15/2007	RJM
STYLE	5	1.05	COLONIAL [100%]	REVIEW	12/15/2020	MR
QUALITY	A	1.00	AVG [100%]			
FRAME	1	1.00	WD FRAME [100%]			

BLDG COMMENTS

INFO @ DOOR 10/29/20

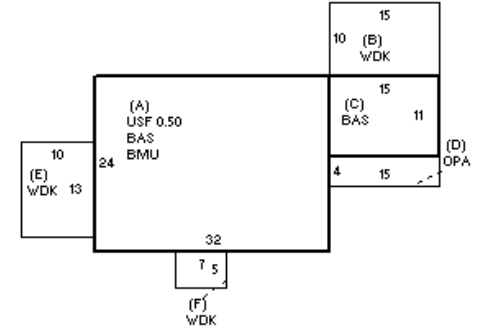

YEAR BLT	1965	SIZE ADJ	1.000
NET AREA	1,317	DETAIL ADJ	1.000
\$NLA(RCN)	\$322	OVERALL	1.050
CAPACITY		UNITS	ADJ
STORIES		1.5	1.00
ROOMS		7	1.00
BEDROOMS		3	1.00
BATHROOMS		2	1.00
FIXTURES		6	\$8,190
GARAGE SPACES		0	1.00
% BSMT FIN		0	1.00
# 1/2 BATHS		0	1.00
# OF UNITS		1	1.00

ELEMENT	CD	DESCRIPTION	ADJ	S	BAT	T	DESCRIPTION	UNITS	YB	ADJ PRICE	RCN
FOUNDATION	4	FLR & WALL	1.00	A	BMU	N	BSMT UNFINISHED	768		65.42	50,242
EXT COVER	1	WD SHINGLE	1.00	A	USF	L	UPPER STORY FIN	384	1965	195.01	74,884
ROOF SHAPE	6	SALTBOX	1.00	+	WDK	N	WOOD DECK	315		41.16	12,965
ROOF COVER	1	ASPH/CMP SH	1.00	+	BAS	L	BASE AREA	933	1965	279.53	260,802
FLOOR COVER	1	HARDWOOD	1.00	D	OPA	N	OPEN PORCH	60		52.50	3,150
INT FINISH	2	DRYWALL	1.00		F21	O	FPL 2S 1OP	1		10,658.60	10,659
HEATING/COOL	2	HOT WATER	1.00		ODS	O	OUTDOOR SHOWER	1		2,535.80	2,536
FUEL SOURCE	1	OIL	1.00								

TOTAL RCN	423,427
CONDITION ELEM	CD
EXTERIOR	A
INTERIOR	A
KITCHEN	A
BATHS	G
HEAT/ELEC	A
EFF.YR/AGE	1969 / 54
COND	32 32 %
FUNC	0
ECON	0
DEPR	32 % GD 68
RCNLD	\$287,900