

Key: 7784

Town of BREWSTER - Fiscal Year 2025

9/17/2024 2:15 pm SEQ #: 8.012

LEG
A
L

L
A
N
D

D
E
T
A
C
H
E
D

B
U
I
L
D
I
N
G

CURRENT OWNER				PARCEL ID				LOCATION				CLASS	CLASS%	DESCRIPTION			BN ID	BN	CARD			
ROY MICHAEL J & YVONNE M 58 OLD FREEMANS WAY BREWSTER, MA 02631				85-90-0				58 OLD FREEMANS WAY				1010	100	SINGLE FAMILY				1	1 of 1			
				TRANSFER HISTORY		DOS		T		SALE PRICE		BK-PG (Cert)		PMT NO	PMT DT	TY	DESC	AMOUNT	INSP	BY	1st	%
				ROY MICHAEL J & YVONNE M		02/11/2002		QS		85,000		14807-252		328	05/12/2015	77	SOLAR PANELS	29,000	04/19/2016	WFF	100	100
				PRATT JOYCE E & PRATT THI		09/11/1967		XX		1386-1080				61	02/07/2006	2	ADD	3,000	08/08/2007	JH	100	100
														665	11/04/2005	2	ADD	25,000	05/17/2006	JB	100	100
														15	01/14/2003	12	CYCLICAL NON OUT BUILDING	1,100	09/15/2003	JB	100	100
																3			04/15/2003	TN	100	100

TOTAL		23,261 SF		ZONING	RM	FRNT	0		ASSESSED	CURRENT	PREVIOUS
Nbhd	NBHD 13	NOTE			LAND	229,800		216,800		216,800	
St Ind	AVERAGE				BUILDING	687,400		656,900		656,900	
Infl	AVERAGE				DETACHED	2,700		2,700		2,700	
					OTHER	0		0		0	
					TOTAL	919,900		876,400		876,400	

TY	QUAL	COND	DIM/NOTE	YB	UNITS	ADJ PRICE	RCNLD	
SHF	G	1.20	20 0.80	8X10	2002	80	26.41	1,700
PTD	A	1.00	50 0.50	16X16		256	8.10	1,000



BLDG COMMENTS
45 SOLAR PANELS
INFO AT DOOR (2/6/2021)

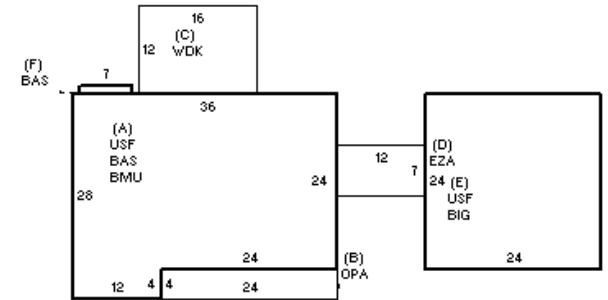

BUILDING	CD	ADJ	DESC	MEASURE	2/6/2021	TCK
MODEL	1		RESIDENTIAL	LIST	8/8/2007	JH
STYLE	5	1.05	COLONIAL [100%]	REVIEW	3/11/2021	MR
QUALITY	G	1.30	GOOD [100%]			
FRAME	1	1.00	WD FRAME [100%]			

YEAR BLT	2002	SIZE ADJ	1.000	ELEMENT	CD	DESCRIPTION	ADJ	S	BAT	T	DESCRIPTION	UNITS	YB	ADJ PRICE	RCN	TOTAL RCN	818,323		
NET AREA	2,407	DETAIL ADJ	1.000	FOUNDATION	3	FOUN WALL	1.00	A	BMU	N	BSMT UNFINISHED	912		80.53	73,448	CONDITION ELEM CD			
\$NLA(RCN)	\$340	OVERALL	1.050	EXT COVER	4	VINYL	1.00	+	USF	L	UPPER STORY FIN	1,488	2002	220.22	327,693	EXTERIOR	A		
				ROOF SHAPE	2	HIP	1.00	B	OPA	N	OPEN PORCH	96		68.25	6,552	INTERIOR	A		
				ROOF COVER	1	ASPH/CMP SH	1.00	C	WDK	N	WOOD DECK	192		53.51	10,273	KITCHEN	A		
				FLOOR COVER	1	HARDWOOD	1.00	D	EZA	N	ENCL BREEZEWAY	84		115.21	9,678	BATHS	A		
				INT FINISH	2	DRYWALL	1.00	E	BIG	N	BUILT-IN GARAGE	576		66.43	38,261	HEAT/ELEC	A		
				HEATING/COOL	1	FORCED AIR	1.00	+	BAS	L	BASE AREA	919	2002	363.39	333,955				
				FUEL SOURCE	2	GAS	1.00	GFP	O	O	GAS FIREPLACE	1		4,267.00	4,267				
CAPACITY				UNITS	ADJ													EFF.YR/AGE	2002 / 21
STORIES	2	1.00														COND	16 16 %		
ROOMS	6	1.00	\$14,196													FUNC	0		
BEDROOMS	2	1.00														ECON	0		
BATHROOMS	2	1.00														DEPR	16 % GD 84		
FIXTURES	8															RCNLD	\$687,400		
GARAGE SPACES	2	1.00																	
% BSMT FIN	0	1.00																	
# 1/2 BATHS	1	1.00																	
# OF UNITS	1	1.00																	