

Key: 7886

Town of BREWSTER - Fiscal Year 2025

9/17/2024 2:15 pm SEQ #: 8.114

LEGALS

CURRENT OWNER				PARCEL ID				LOCATION			
SULLIVAN ALLAN F JR LIFE ESTATE C/O SULLIVAN ALLAN F JR (LIFE ESTATE) 77 ALLEN DRIVE BREWSTER, MA 02631				95-100-0				77 ALLEN DRIVE			
TRANSFER HISTORY				DOS	T	SALE PRICE	BK-PG (Cert)				
SULLIVAN ALLAN F JR (LIFE ESTATE)				03/06/2024	F	1 N/A-N/A					
SULLIVAN ALLAN F JR				03/06/2024	F	1 36250-305					
SULLIVAN ALLAN F JR LIFE ESTATE				09/09/2011	F	1 25671-338					

CLASS	CLASS%	DESCRIPTION			BN ID	BN	CARD	
1010	100	SINGLE FAMILY				1	1 of 1	
PMT NO	PMT DT	TY	DESC	AMOUNT	INSP	BY	1st	%
204	03/12/2018	77	SOLAR PANELS	32,000	07/10/2019	TCK	100	100
20	01/03/2007	12	CYCLICAL NON		02/14/2013	SF	100	100
21	01/23/2004	2	ADD	3,000	09/23/2008	JH	100	100
22	01/23/2004	1	NEW CONSTRUCT	270,000	04/13/2005	JB	100	100
	01/23/2004	1	NEW CONSTRUCT	30,000	04/13/2005	JB	100	100

LAND

CD	T	AC/SF/UN	Nbhd	St Ind	Infl	ADJ BASE	SAF	Topo	Lpi	VC	CREDIT AMT	ADJ VALUE					
100	S	16,300	13	1.00	A	1.00	A	1.00	219,200	2.62	A	1.00	R03	1.00			215,220

TOTAL	16,300 SF	ZONING	RM	FRNT	0	ASSESSED	CURRENT	PREVIOUS
Nbhd	NBHD 13	NOTE				LAND	215,200	203,100
St Ind	AVERAGE		BUILDING	625,500	598,000			
Infl	AVERAGE		DETACHED	26,400	26,200			
			OTHER	0	0			
						TOTAL	867,100	827,300

DETACHED

TY	QUAL	COND	DIM/NOTE	YB	UNITS	ADJ PRICE	RCNLD
SHF	A	1.00	50 0.50 10X8		80	22.01	900
GFL	G	1.20	15 0.85 20X20	2004	400	65.04	22,100
HTB	A	1.00	15 0.85	2007	1	4,058.10	3,400

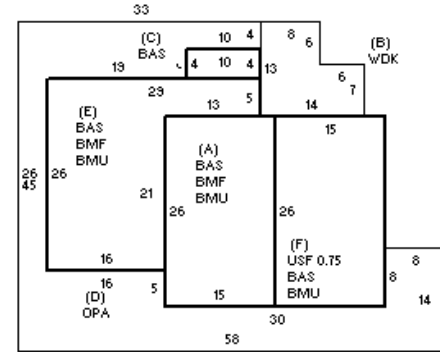

BUILDING

BUILDING	CD	ADJ	DESC	MEASURE	10/7/2020	TCK
MODEL	1		RESIDENTIAL	LIST	10/7/2020	EST
STYLE	4	1.02	CAPE [100%]	REVIEW	1/12/2021	MR
QUALITY	G	1.30	GOOD [100%]			
FRAME	1	1.00	WD FRAME [100%]			

BLDG COMMENTS
 EST 20 SOLAR PANELS
 BMF=FAM RM, ENT RM
 ABOVE GARAGE=LIV RM/FULL BATH
 INFO @ DOOR 10/7/20

YEAR BLT	2004	SIZE ADJ	1.000
NET AREA	1,594	DETAIL ADJ	1.000
\$NLA(RCN)	\$462	OVERALL	1.050
CAPACITY		UNITS	ADJ
STORIES		1.75	1.00
ROOMS		5	1.00
BEDROOMS		2	1.00
BATHROOMS		3	1.00
FIXTURES		11	\$19,520
GARAGE SPACES		0	1.00
% BSMT FIN		0	1.00
# 1/2 BATHS		1	1.00
# OF UNITS		1	1.00

ELEMENT	CD	DESCRIPTION	ADJ
FOUNDATION	4	FLR & WALL	1.00
EXT COVER	1	WD SHINGLE	1.00
ROOF SHAPE	1	GABLE	1.00
ROOF COVER	1	ASPH/CMP SH	1.00
FLOOR COVER	1	HARDWOOD	1.00
INT FINISH	2	DRYWALL	1.00
HEATING/COOL	9	WARM/CL AIR	1.03
FUEL SOURCE	2	GAS	1.00

S	BAT	T	DESCRIPTION	UNITS	YB	ADJ PRICE	RCN
+	BMU	N	BSMT UNFINISHED	1,261		74.17	93,531
+	BMF	N	BSMT FINISH	871		48.59	42,326
B	WDK	N	WOOD DECK	146		53.51	7,812
+	BAS	L	BASE AREA	1,301	2004	336.47	437,751
D	OPA	N	OPEN PORCH	840		68.25	57,330
F	USF	L	UPPER STORY FIN	293	2004	253.51	74,279
	ODS	O	OUTDOOR SHOWER	1		3,296.50	3,297

TOTAL RCN	735,846
CONDITION ELEM	CD
EXTERIOR	A
INTERIOR	A
KITCHEN	A
BATHS	A
HEAT/ELEC	A
EFF.YR/AGE	2004 / 19
COND	15 15 %
FUNC	0
ECON	0
DEPR	15 % GD 85
RCNLD	\$625,500