

Key: 8228

Town of BREWSTER - Fiscal Year 2025

9/17/2024 2:15 pm SEQ #: 8.464

LEG  
AL  
LAND

CURRENT OWNER		PARCEL ID	LOCATION			
O'CONNOR KEVIN B & MICHELE H 1721 LONG POND ROAD BREWSTER, MA 02631		93-42-0	1721-1719 LONG POND ROAD			
TRANSFER HISTORY		DOS	T	SALE PRICE	BK-PG (Cert)	
O'CONNOR KEVIN B & MICHEL CONSTANTINE ATSA LIS & L G		06/27/1997	QS	68,000	10825-048	
		03/20/1992	QS	59,000	N/A-N/A	

CLASS	CLASS%	DESCRIPTION		BN ID	BN	CARD	
1090	100	MULTIPLE HSES			1	1 of 2	
PMT NO	PMT DT	TY	DESC	AMOUNT	INSP	BY	1st %
152	02/18/2022	7	ALTERATIONS	1,844	03/30/2023	TCK	100 100
148	02/24/2020	7	ALTERATIONS	850	01/25/2021	TCK	100 100
127	02/16/2017	77	SOLAR PANELS	31,000	06/19/2018	NF	100 100
		12	CYCLICAL NON		03/25/2013	SF	100 100
582	09/14/2007	1	NEW CONSTRUC	225,000	02/03/2009	JH	100 100

CD	T	AC/SF/UN	Nbhd	St Ind	Infl	ADJ BASE	SAF	Topo	Lpi	VC	CREDIT AMT	ADJ VALUE	
100	S	60,000	13	1.00	A	1.00	A	1.00	197,280	1.00	A	1.00	273,010
300	A	2,953	13	1.00	A	1.00	A	1.00	10,800	1.00	A	1.00	31,890

TOTAL	4.330 Acres	ZONING	RL	FRNT	0	ASSESSED	CURRENT	PREVIOUS
Nbhd	NBHD 13	N O T E	House #1719 issued by FD 7/23/07 for Detached garage apt-- 10/1/07cc			LAND	304,900	287,600
St Ind	AVERAGE		BUILDING	822,100	785,600			
Infl	AVERAGE		DETACHED	4,600	4,500			
			OTHER	334,100	315,400			
						<b>TOTAL</b>	<b>1,465,700</b>	<b>1,393,100</b>

TY	QUAL	COND	DIM/NOTE	YB	UNITS	ADJ PRICE	RCNLD
SHF	G	1.20 20 0.80	12X20		240	23.81	4,600

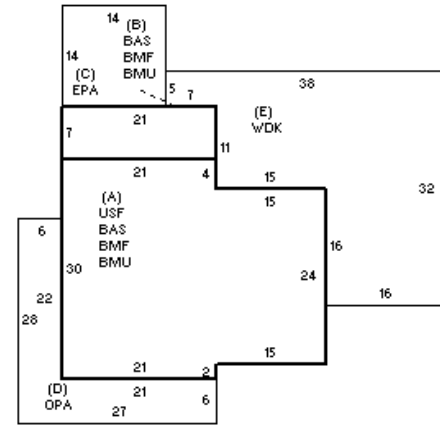

BUILDING	CD	ADJ	DESC	MEASURE	1/25/2021	TCK
MODEL	1		RESIDENTIAL	LIST	3/25/2013	SF
STYLE	5	1.05	COLONIAL [100%]	REVIEW	4/11/2023	EMZ
QUALITY	G+	1.45	GOOD + [100%]			
FRAME	1	1.00	WD FRAME [100%]			

BLDG COMMENTS  
 29 SOLAR PANELS  
 BMF=FAM RM/OFFICE/BATH  
 INFO @ DOOR 1/25/2021

DETACHED

BUILDING

YEAR BLT	1998	SIZE ADJ	1.000	ELEMENT	CD	DESCRIPTION	ADJ	S	BAT	T	DESCRIPTION	UNITS	YB	ADJ PRICE	RCN	TOTAL RCN	1,002.605		
NET AREA	2,127	DETAIL ADJ	1.000	FOUNDATION	4	FLR & WALL	1.00	+	BMU	N	BSMT UNFINISHED	1,137		85.96	97,742	CONDITION ELEM	CD		
\$NLA(RCN)	\$471	OVERALL	1.050	EXT COVER	1	WD SHINGLE	1.00	+	BMF	N	BSMT FINISH	1,137		51.87	58,977	EXTERIOR	A		
				ROOF SHAPE	1	GABLE	1.00	+	BAS	L	BASE AREA	1,137	1998	386.56	439,514	INTERIOR	A		
				ROOF COVER	1	ASPH/CMP SH	1.00	A	USF	L	UPPER STORY FIN	990	1998	277.05	274,281	KITCHEN	A		
				FLOOR COVER	2	SOFTWOOD	1.00	C	EPA	N	ENCLOSED PORCH	196		116.43	22,821	BATHS	A		
				INT FINISH	2	DRYWALL	1.00	D	OPA	N	OPEN PORCH	294		76.13	22,381	HEAT/ELEC	A		
				HEATING/COOL	2	HOT WATER	1.00	E	WDK	N	WOOD DECK	787		59.68	46,969				
				FUEL SOURCE	1	OIL	1.00	F23	O		FPL 2S 3OP	1		30,023.70	30,024				
																		EFF.YR/AGE	1998 / 25
																		COND	18 18 %
																		FUNC	0
																		ECON	0
																		DEPR	18 % GD 82
																		RCNLD	\$822,100

Key: 8228

Town of BREWSTER - Fiscal Year 2025

9/17/2024 2:15 pm SEQ #: 8.465

LEGAL

CURRENT OWNER		PARCEL ID	LOCATION			
O'CONNOR KEVIN B & MICHELE H 1721 LONG POND ROAD BREWSTER, MA 02631		93-42-0	1721-1719 LONG POND ROAD			
TRANSFER HISTORY		DOS	T	SALE PRICE	BK-PG (Cert)	

CLASS	CLASS%	DESCRIPTION			BN ID	BN	CARD	
1090	100	MULTIPLE HSES				2	2 of 2	
PMT NO	PMT DT	TY	DESC	AMOUNT	INSP	BY	1st	%

LAND

CD	T	AC/SF/UN	Nbhd	St Ind	Infl	ADJ BASE	SAF	Topo	Lpi	VC	CREDIT AMT	ADJ VALUE

TOTAL	ZONING	FRNT	ASSESSED	CURRENT	PREVIOUS
Nbhd	NOTE		LAND	334,100	
St Ind			BUILDING		
Infl			DETACHED		
			OTHER		
			TOTAL		

DETACHED

TY	QUAL	COND	DIM/NOTE	YB	UNITS	ADJ PRICE	RCNLD



BLDG COMMENTS  
INFO @ DOOR 1/25/2021

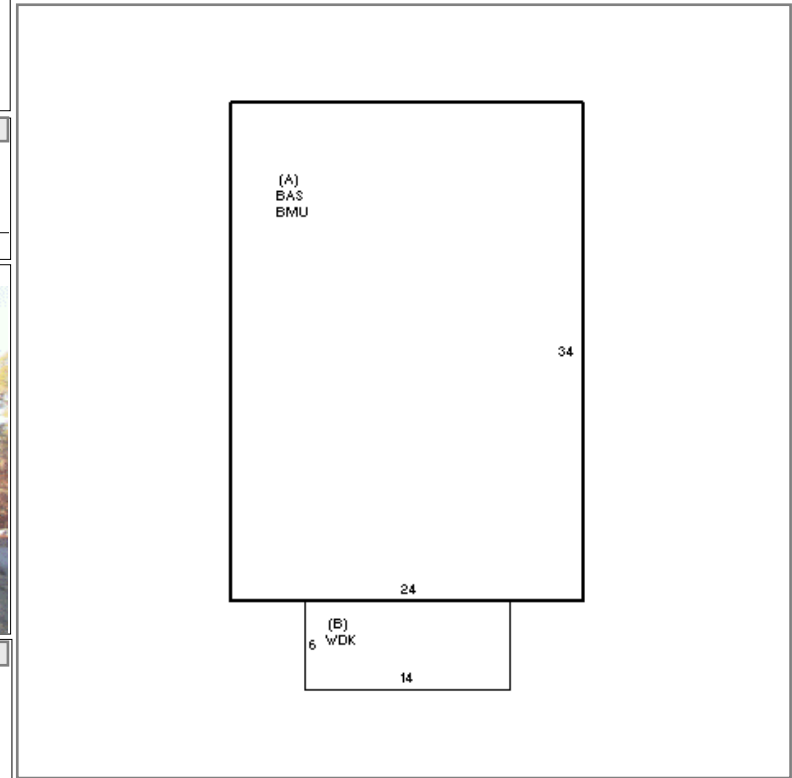

BUILDING

BUILDING	CD	ADJ	DESC	MEASURE	1/25/2021	TCK
MODEL	1		RESIDENTIAL	LIST	3/25/2013	SF
STYLE	1	1.00	RANCH [100%]	REVIEW	4/11/2023	EMZ
QUALITY	G	1.30	GOOD [100%]			
FRAME	1	1.00	WD FRAME [100%]			

YEAR BLT	2007	SIZE ADJ	1.000
NET AREA	816	DETAIL ADJ	1.000
\$NLA(RCN)	\$471	OVERALL	1.030
CAPACITY		UNITS	ADJ
STORIES	1	1.00	
ROOMS	3	1.00	
BEDROOMS	1	1.00	
BATHROOMS	1	1.00	
FIXTURES	3	\$5,222	
GARAGE SPACES	2	1.00	
% BSMT FIN	0	1.00	
# 1/2 BATHS	0	1.00	
# OF UNITS	1	1.00	

ELEMENT	CD	DESCRIPTION	ADJ
FOUNDATION	4	FLR & WALL	1.00
EXT COVER	1	WD SHINGLE	1.00
ROOF SHAPE	1	GABLE	1.00
ROOF COVER	1	ASPH/CMP SH	1.00
FLOOR COVER	1	HARDWOOD	1.00
INT FINISH	2	DRYWALL	1.00
HEATING/COOL	9	WARM/CL AIR	1.03
FUEL SOURCE	2	GAS	1.00

S	BAT	T	DESCRIPTION	UNITS	YB	ADJ PRICE	RCN
A	BMU	N	BSMT UNFINISHED	816		79.00	64,465
A	BAS	L	BASE AREA	816	2007	369.67	301,651
B	WDK	N	WOOD DECK	84		52.49	4,409
	BMG	O	BSMT GARAGE	2		4,142.20	8,284

TOTAL RCN	384.032
CONDITION ELEM	CD
EXTERIOR	A
INTERIOR	A
KITCHEN	A
BATHS	A
HEAT/ELEC	A
EFF.YR/AGE	2007 / 16
COND	13 13 %
FUNC	0
ECON	0
DEPR	13 % GD 87
RCNLD	\$334,100