

Key: 8323

Town of BREWSTER - Fiscal Year 2025

9/17/2024 2:15 pm SEQ #: 8.563

LEGAL LAND

Table with columns: CURRENT OWNER, PARCEL ID, LOCATION, TRANSFER HISTORY, DOS, T, SALE PRICE, BK-PG (Cert), CD, T, AC/SF/UN, Nbhd, St Ind, Infl, ADJ BASE, SAF, Topo, Lpi, VC, CREDIT AMT, ADJ VALUE.

Table with columns: CLASS, CLASS%, DESCRIPTION, BN ID, BN, CARD, PMT NO, PMT DT, TY, DESC, AMOUNT, INSP, BY, 1st, %.

Table with columns: TOTAL, ZONING, RR, FRNT, ASSESSED, CURRENT, PREVIOUS, Nbhd, St Ind, Infl, TOPO - Development Restriction Line, LAND, BUILDING, DETACHED, OTHER, TOTAL.

Table with columns: TY, QUAL, COND, DIM/NOTE, YB, UNITS, ADJ PRICE, RCNLD, PHOTO 06/03/2024.

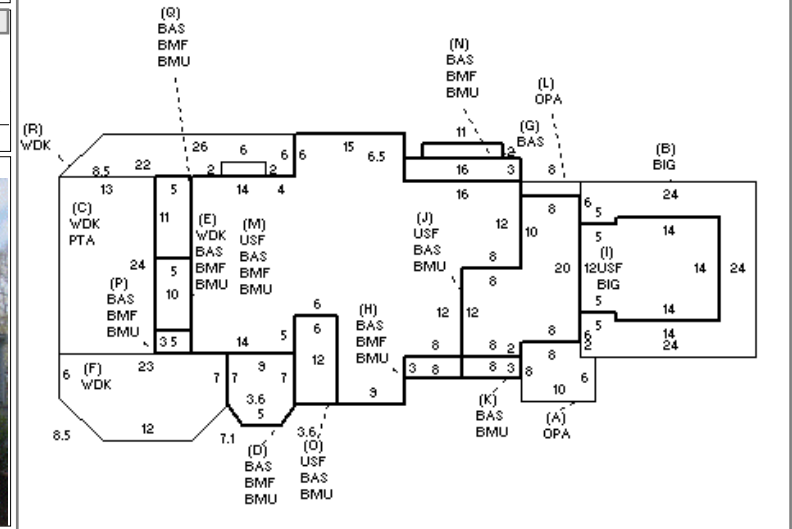

Table with columns: BUILDING, CD, ADJ, DESC, MEASURE, LIST, REVIEW, MODEL, STYLE, QUALITY, FRAME.

BLDG COMMENTS: 2 FULL BATHS HAVE 4 FIX, EXTRA FIX IN KITCHEN & LAUNDRY; 20 SOLAR PANELS.

DETACHED

BUILDING

Table with columns: YEAR BLT, SIZE ADJ, NET AREA, \$NLA(RCN), CAPACITY, UNITS, ADJ, ELEMENT, CD, DESCRIPTION, ADJ, S, BAT, T, DESCRIPTION, UNITS, YB, ADJ PRICE, RCN, TOTAL RCN, CONDITION ELEM, CD, EFF. YR/AGE, COND, FUNC, ECON, DEPR, RCNLD.

Key: 8323

Town of BREWSTER - Fiscal Year 2025

9/17/2024 2:15 pm SEQ #: 8.564

LEG
A
L

L
A
N
D

D
E
T
A
C
H
E
D

B
U
I
L
D
I
N
G

CURRENT OWNER				PARCEL ID				LOCATION			
SCHLEGEL ROBERT & FOGEL JANET B 15 KINGS WAY UNIT 14 WALTHAM, MA 02451				82-3-0				286 LANDING DRIVE			
TRANSFER HISTORY				DOS	T	SALE PRICE	BK-PG (Cert)				

CLASS	CLASS%	DESCRIPTION			BN ID	BN	CARD	
1010	100	SINGLE FAMILY				2	2 of 2	
PMT NO	PMT DT	TY	DESC	AMOUNT	INSP	BY	1st	%

CD	T	AC/SF/UN	Nbhd	St Ind	Infl	ADJ BASE	SAF	Topo	Lpi	VC	CREDIT AMT	ADJ VALUE

TOTAL	ZONING	FRNT	ASSESSED	CURRENT	PREVIOUS
Nbhd	NOTE		LAND BUILDING DETACHED OTHER TOTAL	164,500	
St Ind					
Infl					

TY	QUAL	COND	DIM/NOTE	YB	UNITS	ADJ PRICE	RCNLD

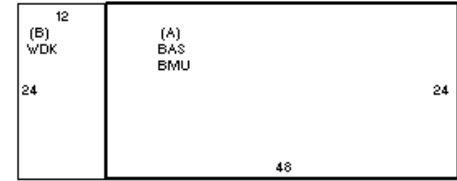

BUILDING	CD	ADJ	DESC	MEASURE	10/27/2017	JMG
MODEL	1		RESIDENTIAL	LIST	10/27/2017	JMG
STYLE	1	1.00	RANCH [100%]	REVIEW	6/3/2024	EMZ
QUALITY	L	0.75	LOW COST [100%]			
FRAME	1	1.00	WD FRAME [100%]			

BLDG COMMENTS
USE LIMITED TO BUNKHOUSE - NO KITCHEN

YEAR BLT	1965	SIZE ADJ	1.000
NET AREA	1,152	DETAIL ADJ	1.000
\$NLA(RCN)	\$255	OVERALL	1.000
CAPACITY		UNITS	ADJ
STORIES	1	1.00	
ROOMS	4	1.00	
BEDROOMS	1	1.00	
BATHROOMS	1	1.00	
FIXTURES	3	\$2,925	
GARAGE SPACES	0	1.00	
% BSMT FIN	0	1.00	
# 1/2 BATHS	0	1.00	
# OF UNITS	0	1.00	

ELEMENT	CD	DESCRIPTION	ADJ
FOUNDATION	4	FLR & WALL	1.00
EXT COVER	1	WD SHINGLE	1.00
ROOF SHAPE	1	GABLE	1.00
ROOF COVER	1	ASPH/CMP SH	1.00
FLOOR COVER	4	ASPH TILE	1.00
INT FINISH	2	DRYWALL	1.00
HEATING/COOL	1	FORCED AIR	1.00
FUEL SOURCE	2	GAS	1.00

S	BAT	T	DESCRIPTION	UNITS	YB	ADJ PRICE	RCN
A	BMU	N	BSMT UNFINISHED	1,152		42.35	48,784
A	BAS	L	BASE AREA	1,152	1965	190.42	219,365
B	WDK	N	WOOD DECK	288		29.40	8,468
	F12	O	FPL 1S 2OP	2		7,104.40	14,209

TOTAL RCN	293,750
CONDITION ELEM	CD
EXTERIOR	A
INTERIOR	A
KITCHEN	
BATHS	A
HEAT/ELEC	A
EFF.YR/AGE	1965 / 58
COND	34 34 %
FUNC	10 NO KITCHEN
ECON	0
DEPR	44 % GD 56
RCNLD	\$164,500