

Key: 8349

Town of BREWSTER - Fiscal Year 2025

9/17/2024 2:15 pm SEQ #: 8.590

LEG  
A  
L  
L  
A  
N  
D

CURRENT OWNER				PARCEL ID				LOCATION					
CAPECATION LLC 32 BEECHTREE DRIVE BREWSTER, MA 02631				82-41-0				307 GREENLAND POND ROAD					
TRANSFER HISTORY				DOS	T	SALE PRICE		BK-PG (Cert)					
CAPECATION LLC				12/02/2022	QS	700,000 (231712)							
YOUNG ROBERT C & CHASE EL				06/01/2004	QS	425,000 (173238)							
KOWALCZYK-AYRES MARGARET				09/26/1994	A	100 (135087)							
CD	T	AC/SF/UN	Nbhd	St Ind	Infl	ADJ BASE	SAF	Topo	Lpi	VC	CREDIT AMT	ADJ VALUE	
100	S	31,300	17	1.00	A	1.00	A	1.00	A	1.00	R05	1.15	283,400

CLASS	CLASS%	DESCRIPTION			BN ID	BN	CARD	
1010	100	SINGLE FAMILY				1	1 of 1	
PMT NO	PMT DT	TY	DESC	AMOUNT	INSP	BY	1st	%
23-654	05/17/2023	7	ALTERATIONS	2,200	05/14/2024	TCK	100	100
	12/02/2022	16	MLS REVIEW	700,000	07/13/2023	JMG	100	100
		12	CYCLICAL NON		05/19/2016	WFF	100	100
643	10/28/2005	2	ADD	94,000	05/31/2006	JB	100	100
		12	CYCLICAL NON		03/15/2004	JB	100	100

TOTAL	31,300 SF	ZONING	RR	FRNT	0	ASSESSED	CURRENT	PREVIOUS
Nbhd	NBHD 17	NOTE				LAND	283,400	267,400
St Ind	AVERAGE		BUILDING	413,300	395,400			
Infl	AVERAGE		DETACHED	3,300	3,200			
			OTHER	0	0			
						TOTAL	700,000	666,000

TY	QUAL	COND	DIM/NOTE	YB	UNITS	ADJ PRICE	RCNLD
SHF	A	1.00	50 0.50 8X8		64	22.01	700
SHF	A	1.00	01 1.00 10X12	2003	120	21.39	2,600

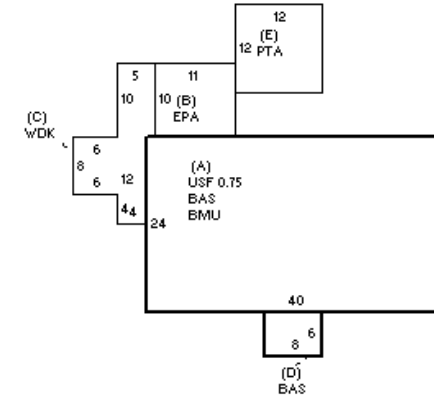

BUILDING	CD	ADJ	DESC	MEASURE	5/19/2016	WFF
MODEL	1		RESIDENTIAL	LIST	5/31/2006	JB
STYLE	4	1.02	CAPE [100%]	REVIEW	6/3/2024	EMZ
QUALITY	+	1.10	PLUS AVE [100%]			
FRAME	1	1.00	WD FRAME [100%]			

BLDG COMMENTS

D  
E  
T  
A  
C  
H  
E  
D

B  
U  
I  
L  
D  
I  
N  
G

YEAR BLT	1971	SIZE ADJ	1.000	ELEMENT	CD	DESCRIPTION	ADJ	S	BAT	T	DESCRIPTION	UNITS	YB	ADJ PRICE	RCN	TOTAL RCN	543,829
NET AREA	1,728	DETAIL ADJ	1.000	FOUNDATION	4	FLR & WALL	1.00	A	BMU	N	BSMT UNFINISHED	960		66.20	63,550		
\$NLA(RCN)	\$315	OVERALL	1.020	EXT COVER	1	WD SHINGLE	1.00	A	BAS	L	BASE AREA	960	1971	293.17	281,440		
				ROOF SHAPE	1	GABLE	1.00	A	USF	L	UPPER STORY FIN	720	2005	206.28	148,520		
				ROOF COVER	1	ASPH/CMP SH	1.00	B	EPA	N	ENCLOSED PORCH	110		90.32	9,935		
				FLOOR COVER	1	HARDWOOD	1.00	C	WDK	N	WOOD DECK	146		43.98	6,421		
				INT FINISH	2	DRYWALL	1.00	D	BAS	L	BASE AREA	48	2005	293.17	14,072		
				HEATING/COOL	2	HOT WATER	1.00	E	PTA	N	PATIO	144		17.84	2,569		
				FUEL SOURCE	1	OIL	1.00	F11	O	O	FPL 1S 1OP	1		8,568.70	8,569		
																CONDITION ELEM	CD
																EXTERIOR	A
																INTERIOR	A
																KITCHEN	A
																BATHS	A
																HEAT/ELEC	A
																EFF.YR/AGE	1986 / 37
																COND	24 24 %
																FUNC	0
																ECON	0
																DEPR	24 % GD 76
																RCNLD	\$413,300