

Key: 8360

Town of BREWSTER - Fiscal Year 2025

9/17/2024 2:15 pm SEQ #: 8.600

LEGALS

CURRENT OWNER				PARCEL ID				LOCATION								
SMITH DOUGLAS KENT & SMITH NANCY GUSTAFSON 21 VALLEY ROAD BREWSTER, MA 02631				82-15-0				21 VALLEY ROAD								
				TRANSFER HISTORY				DOS	T	SALE PRICE	BK-PG (Cert)					
				SMITH DOUGLAS KENT & KAUTZ E LADD & CATHERINE				10/26/2001 03/21/1984	QS XX	283,500	(163236) (95756)					
CD	T	AC/SF/UN	Nbhd	St Ind	Infl	ADJ BASE	SAF	Topo	Lpi	VC	CREDIT AMT	ADJ VALUE				
100	S	19,100	17	1.00	A	1.00	A	1.00	295,920	2.30	A	1.00	R06	1.35		298,600

LAND

TOTAL	19,100 SF	ZONING	RR	FRNT	0	ASSESSED	CURRENT	PREVIOUS
Nbhd	NBHD 17	NOTE				LAND	298,600	281,700
St Ind	AVERAGE		BUILDING	411,800	394,000			
Infl	AVERAGE		DETACHED	0	0			
			OTHER	0	0			
						TOTAL	710,400	675,700

DETACHED

TY	QUAL	COND	DIM/NOTE	YB	UNITS	ADJ PRICE	RCNLD	PHOTO	06/06/2018
									

BUILDING

BUILDING	CD	ADJ	DESC	MEASURE	5/23/2016	WFF	BLDG COMMENTS
MODEL	1		RESIDENTIAL	LIST	6/14/2007	JH	OUTDOOR SHOWER
STYLE	5	1.05	COLONIAL [100%]	REVIEW	6/19/2018	TD	
QUALITY	A	1.00	AVG [100%]				
FRAME	1	1.00	WD FRAME [100%]				

G

YEAR BLT	1984	SIZE ADJ	1.000	ELEMENT	CD	DESCRIPTION	ADJ	S	BAT	T	DESCRIPTION	UNITS	YB	ADJ PRICE	RCN	TOTAL RCN	521,272																														
NET AREA	1,672	DETAIL ADJ	1.000	FOUNDATION	4	FLR & WALL	1.00	+	BMU	N	BSMT UNFINISHED	1,064		59.29	63,081																																
\$NLA(RCN)	\$312	OVERALL	1.050	EXT COVER	1	WD SHINGLE	1.00	A	BAS	L	BASE AREA	608	1984	274.35	166,807																																
				ROOF SHAPE	6	SALTBOX	1.00	A	USF	L	UPPER STORY FIN	608	1984	193.04	117,369																																
				ROOF COVER	1	ASPH/CMP SH	1.00	+	WDK	N	WOOD DECK	473		41.16	19,469																																
				FLOOR COVER	1	HARDWOOD	1.00	D	BAS	L	BASE AREA	456	1984	274.35	125,105																																
				INT FINISH	2	DRYWALL	1.00		BMG	O	BSMT GARAGE	2		3,248.20	6,496																																
				HEATING/COOL	2	HOT WATER	1.00		F21	O	FPL 2S 1OP	1		10,658.60	10,659																																
				FUEL SOURCE	1	OIL	1.00																																								
				<table border="1"> <thead> <tr> <th>CAPACITY</th> <th>UNITS</th> <th>ADJ</th> </tr> </thead> <tbody> <tr> <td>STORIES</td> <td>1.5</td> <td>1.00</td> </tr> <tr> <td>ROOMS</td> <td>7</td> <td>1.00</td> </tr> <tr> <td>BEDROOMS</td> <td>4</td> <td>1.00</td> </tr> <tr> <td>BATHROOMS</td> <td>2</td> <td>1.00</td> </tr> <tr> <td>FIXTURES</td> <td>9</td> <td>\$12,285</td> </tr> <tr> <td>GARAGE SPACES</td> <td>2</td> <td>1.00</td> </tr> <tr> <td>% BSMT FIN</td> <td>0</td> <td>1.00</td> </tr> <tr> <td># 1/2 BATHS</td> <td>1</td> <td>1.00</td> </tr> <tr> <td># OF UNITS</td> <td>1</td> <td>1.00</td> </tr> </tbody> </table>														CAPACITY	UNITS	ADJ	STORIES	1.5	1.00	ROOMS	7	1.00	BEDROOMS	4	1.00	BATHROOMS	2	1.00	FIXTURES	9	\$12,285	GARAGE SPACES	2	1.00	% BSMT FIN	0	1.00	# 1/2 BATHS	1	1.00	# OF UNITS	1	1.00
CAPACITY	UNITS	ADJ																																													
STORIES	1.5	1.00																																													
ROOMS	7	1.00																																													
BEDROOMS	4	1.00																																													
BATHROOMS	2	1.00																																													
FIXTURES	9	\$12,285																																													
GARAGE SPACES	2	1.00																																													
% BSMT FIN	0	1.00																																													
# 1/2 BATHS	1	1.00																																													
# OF UNITS	1	1.00																																													

CLASS	CLASS%	DESCRIPTION			BN ID	BN	CARD	
1010	100	SINGLE FAMILY				1	1 of 1	
PMT NO	PMT DT	TY	DESC	AMOUNT	INSP	BY	1st	%
015	01/04/2017	5	OTHER	1,500	06/06/2018	NF	100	100
719	09/21/2015	12	CYCLICAL NON		05/23/2016	WFF	100	100
564	11/09/2010	77	SOLAR PANELS	26,930	04/21/2016	WFF	100	100
NP		7	ALTERATIONS	15,000	01/20/2011	JH	100	100
		12	CYCLICAL NON		04/03/2007	JH	100	100

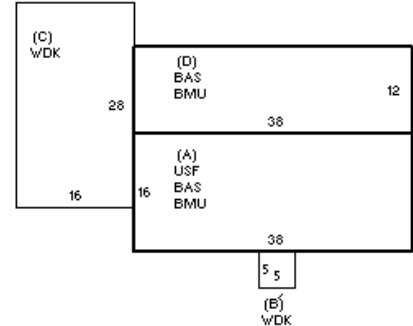

BLDG COMMENTS
OUTDOOR SHOWER

CONDITION ELEM	CD
EXTERIOR	G
INTERIOR	G
KITCHEN	A
BATHS	A
HEAT/ELEC	A

EFF.YR/AGE	1991 / 32	
COND	21	21 %
FUNC	0	
ECON	0	
DEPR	21	% GD 79

RCNLD	\$411,800
-------	-----------