

Key: 8387

Town of BREWSTER - Fiscal Year 2025

9/17/2024 2:15 pm SEQ #: 8.627

LEG  
AL  
LAND

CURRENT OWNER		PARCEL ID		LOCATION								
MOSKOVITZ ANDREW G & HEIDI F 82 WOODBRIDGE STREET SOUTH HADLEY, MA 01075		51-66-0		22 SUMMER LANE								
TRANSFER HISTORY		DOS	T	SALE PRICE	BK-PG (Cert)							
MOSKOVITZ ANDREW G & HEIDI		09/21/2020	QS	570,000 (223789)								
MACDONALD RALPH J & MARY		05/26/2006	F	10 (180170)								
MACDONALD RALPH J & MARY		09/23/1993	P	55,000 (131461)								
CD	T	AC/SF/UN	Nbhd	St Ind	Infl	ADJ BASE	SAF	Topo	Lpi	VC	CREDIT AMT	ADJ VALUE
100	S	20,100	14	1.00	A	252,080	2.20	A	1.00	R03	1.15	256,450

CLASS	CLASS%	DESCRIPTION		BN ID	BN	CARD	
1010	100	SINGLE FAMILY			1	1 of 1	
PMT NO	PMT DT	TY	DESC	AMOUNT	INSP	BY	1st %
23-574	05/09/2023	77	SOLAR PANELS		07/10/2024	TCK	100 100
22-998	01/03/2023	7	ALTERATIONS	340,000	07/10/2024	TCK	100 100
567	06/16/2021	7	ALTERATIONS	1,500	05/03/2022	TCK	100 100
	09/21/2020	15	SALE REVIEW	570,000	03/14/2021	JMG	100 100
NP		12	CYCLICAL NON		04/23/2007	JH	100 100

LAND

TOTAL	20,100 SF	ZONING	RL	FRNT	0	ASSESSED	CURRENT	PREVIOUS
Nbhd	NBHD 14	N O T E	SEASONAL POND VIEW			LAND	256,500	263,000
St Ind	AVERAGE					BUILDING	592,100	446,400
Infl	AVERAGE					DETACHED	0	0
						OTHER	0	0
						<b>TOTAL</b>	<b>848,600</b>	<b>709,400</b>

DETACHED

TY	QUAL	COND	DIM/NOTE	YB	UNITS	ADJ PRICE	RCNLD	PHOTO	07/10/2024
									

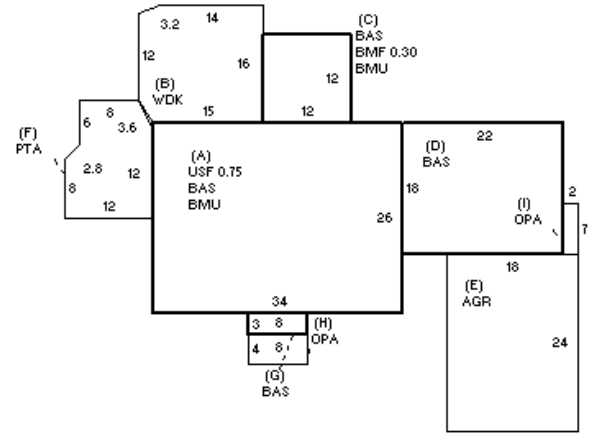

BUILDING

BUILDING	CD	ADJ	DESC	MEASURE	9/6/2017	NF
MODEL	1		RESIDENTIAL	LIST	4/23/2007	JH
STYLE	4	1.02	CAPE [100%]	REVIEW	7/26/2024	EMZ
QUALITY	A	1.00	AVG [100%]	BLDG COMMENTS 20 SOLAR PANELS		
FRAME	1	1.00	WD FRAME [100%]			

BLDG

YEAR BLT	1993	SIZE ADJ	1.000	ELEMENT	CD	DESCRIPTION	ADJ	S	BAT	T	DESCRIPTION	UNITS	YB	ADJ PRICE	RCN	TOTAL RCN	616,732			
NET AREA	2,111	DETAIL ADJ	1.000	FOUNDATION	4	FLR & WALL	1.00	+	BMU	N	BSMT UNFINISHED	1,028		59.29	60,946	CONDITION ELEM CD				
\$NLA(RCN)	\$292	OVERALL	1.050	EXT COVER	4	VINYL	1.00	A	USF	L	UPPER STORY FIN	663	1993	193.04	127,986	EXTERIOR	G			
				ROOF SHAPE	1	GABLE	1.00	B	WDK	N	WOOD DECK	268		41.16	11,031	INTERIOR	V			
				ROOF COVER	1	ASPH/CMP SH	1.00	C	BMF	N	BSMT FINISH	43		42.34	1,821	KITCHEN	V			
				FLOOR COVER	1	HARDWOOD	1.00	+	BAS	L	BASE AREA	1,448	1993	253.65	367,283	BATHS	V			
				INT FINISH	2	DRYWALL	1.00	E	AGR	N	ATT GARAGE	432		42.54	18,377	HEAT/ELEC	G			
				HEATING/COOL	9	WARM/CL AIR	1.03	F	PTA	N	PATIO	174		15.86	2,759					
				FUEL SOURCE	2	GAS	1.00	+	OPA	N	OPEN PORCH	46		52.50	2,415					
													F21	O	FPL 2S 1OP	1	10,658.60	10,659		
													ODS	O	OUTDOOR SHOWER	1	2,535.80	2,536		
													EFF.YR/AGE		2019 / 4					
													COND	4 4 %						
													FUNC	0						
													ECON	0						
													DEPR	4	% GD	96				
													RCNLD			\$592,100				