

Key: 8444

Town of BREWSTER - Fiscal Year 2025

9/17/2024 2:15 pm SEQ #: 8.683

LEG
AL
LAND

CURRENT OWNER				PARCEL ID				LOCATION			
ADELSON DAWN 304 HIGHLAND STREET WESTON, MA 02493				51-99-0				230 LAKE SHORE DRIVE			
TRANSFER HISTORY				DOS	T	SALE PRICE	BK-PG (Cert)				
ADELSON DAWN				11/01/2018	QS	995,000	(217751)				
GROOM ALBERT &				08/10/2017	QS	750,000	(213730)				
DORN CHARLES F & CATHERIN				09/25/2001	F	100	(162882)				

CLASS	CLASS%	DESCRIPTION			BN ID	BN	CARD	
1010	100	SINGLE FAMILY				1	1 of 1	
PMT NO	PMT DT	TY	DESC	AMOUNT	INSP	BY	1st	%
376	06/22/2020	7	ALTERATIONS	65,391	12/21/2020	NF	100	100
116	02/06/2019	7	ALTERATIONS	128,927	07/07/2020	MR	100	100
	11/01/2018	16	MLS REVIEW	995,000	07/24/2019	JMG	100	100
	03/27/2018	77	SOLAR PANELS	30,000	07/16/2019	NF	100	100
	08/10/2017	15	SALE REVIEW	750,000	07/24/2018	JMG	100	100

CD	T	AC/SF/UN	Nbhd	St Ind	Infl	ADJ BASE	SAF	Topo	Lpi	VC	CREDIT AMT	ADJ VALUE					
100	S	31,500	14	1.00	A	1.00	A	1.00	613,760	1.56	A	1.00	PF4	2.80			691,230

TOTAL	31,500 SF	ZONING	RL	FRNT	0	ASSESSED	CURRENT	PREVIOUS
Nbhd	NBHD 14	NOTE				LAND	691,200	652,100
St Ind	AVERAGE		BUILDING	677,400	639,700			
Infl	AVERAGE		DETACHED	0	0			
			OTHER	0	0			
TOTAL						1,368,600	1,291,800	

TY	QUAL	COND	DIM/NOTE	YB	UNITS	ADJ PRICE	RCNLD



BLDG COMMENTS
LLF=FAM RM/BATH (PER PLANS 1/26/21)
30 SOLAR PANELS

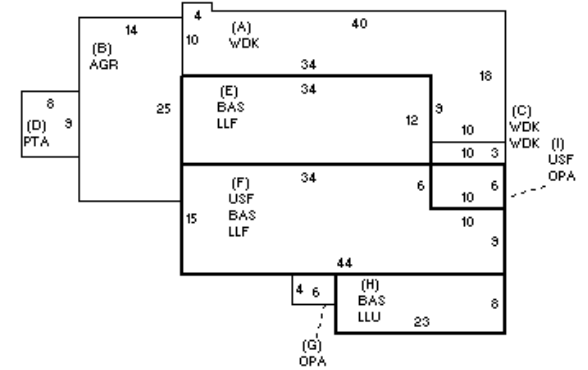

DETACHED

BUILDING

BUILDING	CD	ADJ	DESC	MEASURE	9/5/2017	NF
MODEL	1		RESIDENTIAL	LIST	9/5/2017	EST
STYLE	8	0.95	CONTEMPOR [100%]	REVIEW	1/26/2021	MR
QUALITY	+	1.10	PLUS AVE [100%]			
FRAME	1	1.00	WD FRAME [100%]			

YEAR BLT	1989	SIZE ADJ	0.990	ELEMENT	CD	DESCRIPTION	ADJ	S	BAT	T	DESCRIPTION	UNITS	YB	ADJ PRICE	RCN
NET AREA	2,860	DETAIL ADJ	1.000	FOUNDATION	4	FLR & WALL	1.00	+	WDK	N	WOOD DECK	550		42.69	23,479
\$NLA(RCN)	\$242	OVERALL	1.000	EXT COVER	1	WD SHINGLE	1.00	B	AGR	N	ATT GARAGE	350		46.00	16,099
				ROOF SHAPE	6	SALTBOX	1.00	D	PTA	N	PATIO	72		22.51	1,620
				ROOF COVER	1	ASPH/CMP SH	1.00	+	LLF	L	LOWER LEVEL FIN	1,008	1989	133.53	134,597
				FLOOR COVER	3	W/W CARPET	1.00	E	BAS	L	BASE AREA	408	1989	276.49	112,808
				INT FINISH	2	DRYWALL	1.00	+	BAS	L	BASE AREA	784	1989	276.49	216,770
				HEATING/COOL	11	HTWT/CL AIR	1.05	+	USF	L	UPPER STORY FIN	660	1989	200.21	132,139
				FUEL SOURCE	2	GAS	1.00	+	OPA	N	OPEN PORCH	84		54.45	4,574
								H	LLU	N	LOWER LEVEL UNF	184		103.98	19,132
								F21	O	FPL 2S 1OP	1		11,054.40	11,054	
								GFP	O	GAS FIREPLACE	1		3,404.20	3,404	
								ODS	O	OUTDOOR SHOWER	1		2,629.90	2,630	

TOTAL RCN	691,176
CONDITION ELEM CD	
EXTERIOR	A
INTERIOR	E
KITCHEN	E
BATHS	E
HEAT/ELEC	G
EFF.YR/AGE 2021 / 2	
COND	2 2 %
FUNC	0
ECON	0
DEPR	2 % GD 98
RCNLD	\$677,400