

Key: 8557

Town of BREWSTER - Fiscal Year 2025

9/17/2024 2:15 pm SEQ #: 8.785

LEGALS

LAND

CURRENT OWNER				PARCEL ID				LOCATION					
CORREIA RICHARD A SR & CORREIA CHERYL A 242 CRANVIEW ROAD BREWSTER, MA 02631				20-10-0				242 CRANVIEW ROAD					
				TRANSFER HISTORY		DOS	T	SALE PRICE	BK-PG (Cert)				
				CORREIA RICHARD A SR &		11/17/1989	A	100	6958-256				

CLASS	CLASS%	DESCRIPTION			BN ID	BN	CARD	
1010	100	SINGLE FAMILY				1	1 of 1	
PMT NO	PMT DT	TY	DESC	AMOUNT	INSP	BY	1st	%
128	02/17/2022	9	HVAC	36,985	03/21/2023	TCK	100	100
780	10/06/2017	7	ALTERATIONS	29,000	05/16/2018	NF	100	100
431	06/30/2006	2	ADD	5,000	11/01/2007	JH	100	100

CD	T	AC/SF/UN	Nbhd	St Ind	Infl	ADJ BASE	SAF	Topo	Lpi	VC	CREDIT AMT	ADJ VALUE
100	S	35,719	12	1.00	A	175,360	1.42	A	1.00	R01	0.80	204,490
350	A	0.940	12	1.00	A	2,100	1.00	A	1.00	TWP	1.00	1,970

TOTAL	1.760 Acres	ZONING	RR	FRNT	0	ASSESSED	CURRENT	PREVIOUS
Nbhd	NBHD 12	N O T E	.94 BOG			LAND	206,500	194,800
St Ind	AVERAGE		LAND	772,900	729,700			
Infl	AVERAGE		DETACHED	0	0			
			OTHER	0	0			
			TOTAL	979,400	924,500			

TY	QUAL	COND	DIM/NOTE	YB	UNITS	ADJ PRICE	RCNLD



BLDG COMMENTS
+ 2 FIX BMF=FAMRM W WD STOVE

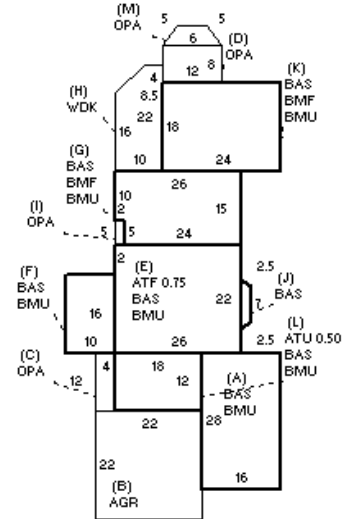

DETACHED

BUILDING

BUILDING	CD	ADJ	DESC	MEASURE	12/13/2017	NF
MODEL	1		RESIDENTIAL	LIST	2/10/2018	NF
STYLE	1	1.00	RANCH [100%]	REVIEW	4/7/2023	EMZ
QUALITY	G	1.30	GOOD [100%]			
FRAME	1	1.00	WD FRAME [100%]			

YEAR BLT	1989	SIZE ADJ	1.000	ELEMENT	CD	DESCRIPTION	ADJ
NET AREA	2,225	DETAIL ADJ	1.000	FOUNDATION	4	FLR & WALL	1.00
\$NLA(RCN)	\$434	OVERALL	1.010	EXT COVER	2	CLAPBOARD	1.00
CAPACITY				ROOF SHAPE	1	GABLE	1.00
STORIES	1.75	UNITS	1.00	ROOF COVER	1	ASPH/CMP SH	1.00
ROOMS	7	ADJ	1.00	FLOOR COVER	1	HARDWOOD	1.00
BEDROOMS	3		1.00	INT FINISH	2	DRYWALL	1.00
BATHROOMS	2		1.00	HEATING/COOL	15	HTWT+DCTLS AC	1.01
FIXTURES	7	\$11,948		FUEL SOURCE	1	OIL	1.00
GARAGE SPACES	2		1.00				
% BSMT FIN	37		1.00				
# 1/2 BATHS	0		1.00				
# OF UNITS	1		1.00				

S	BAT	T	DESCRIPTION	UNITS	YB	ADJ PRICE	RCN
+	BMU	N	BSMT UNFINISHED	2,208		60.27	133,075
B	AGR	N	ATT GARAGE	484		52.06	25,199
+	OPA	N	OPEN PORCH	190		65.65	12,474
E	ATF	N	ATTIC FINISH	429		101.10	43,372
+	BMF	N	BSMT FINISH	812		46.74	37,955
G	BAS	L	BASE AREA	380	1989	291.29	110,690
H	WDK	N	WOOD DECK	202		51.47	10,396
+	BAS	L	BASE AREA	1,845	1989	291.29	537,428
L	ATU	N	ATTIC UNF	108		70.11	7,572
	F23	O	FPL 2S 3OP	1		25,892.40	25,892
	WPL	O	WHIRLPOOL	1		10,154.70	10,155

TOTAL RCN	966,157
CONDITION ELEM	CD
EXTERIOR	A
INTERIOR	G
KITCHEN	A
BATHS	A
HEAT/ELEC	A
EFF.YR/AGE	1993 / 30
COND	20 20 %
FUNC	0
ECON	0
DEPR	20 % GD 80
RCNLD	\$772,900