

Key: 860

Town of BREWSTER - Fiscal Year 2025

9/17/2024 2:15 pm SEQ #: 891

LEGAL

LAND

DETACHED

BUILDING

CURRENT OWNER					PARCEL ID				LOCATION								
FORNO DANIEL J & MARY P 16 ROBERT ROAD BREWSTER, MA 02631					90-144-0				16 ROBERT ROAD								
TRANSFER HISTORY					DOS	T	SALE PRICE	BK-PG (Cert)									
FORNO DANIEL J & MARY P					06/19/2000	QS	350,000	13080-143									
MILLER TOMI L					03/08/2000	A	1	12871-060									
MILLER KEITH D & TOMI L					04/28/1995	S	180,000	9647-122									
CD	T	AC/SF/UN	Nbhd	St Ind	Infl	ADJ BASE	SAF	Topo	Lpi	VC	CREDIT AMT	ADJ VALUE					
100	S	21,057	6	1.00	A	1.00	A	1.00	767,200	2.13	A	1.00	BAV	3.50			788,280

CLASS	CLASS%	DESCRIPTION			BN ID	BN	CARD	
1010	100	SINGLE FAMILY				1	1 of 1	
PMT NO	PMT DT	TY	DESC	AMOUNT	INSP	BY	1st	%
352	08/27/2009	10	INGROUND POO	35,000	04/19/2010	JH	100	100
485	09/08/2008	6	DEMO	14,000	04/08/2009	JH	100	100
440	08/12/2008	1	NEW CONSTRUC	749,030	04/19/2010	JH	100	100

TOTAL	21,057 SF	ZONING	RM	FRNT	0	ASSESSED	CURRENT	PREVIOUS
Nbhd	NBHD 6	NOTE COMBINED W/LOT 62 & PART OF 61 F/Y 97 SUBDIV LOTS 24-2, A & 25 ON PLAN 512/51	LAND	788,300	743,700			
St Ind	AVERAGE		BUILDING	1,076,600	1,028,400			
Infl	AVERAGE		DETACHED	19,700	19,500			
			OTHER	0	0			
TOTAL				1,884,600	1,791,600			

TY	QUAL	COND	DIM/NOTE	YB	UNITS	ADJ PRICE	RCNLD
IPG	G	1.20	10 0.90 15X16	2009	240	90.99	19,700

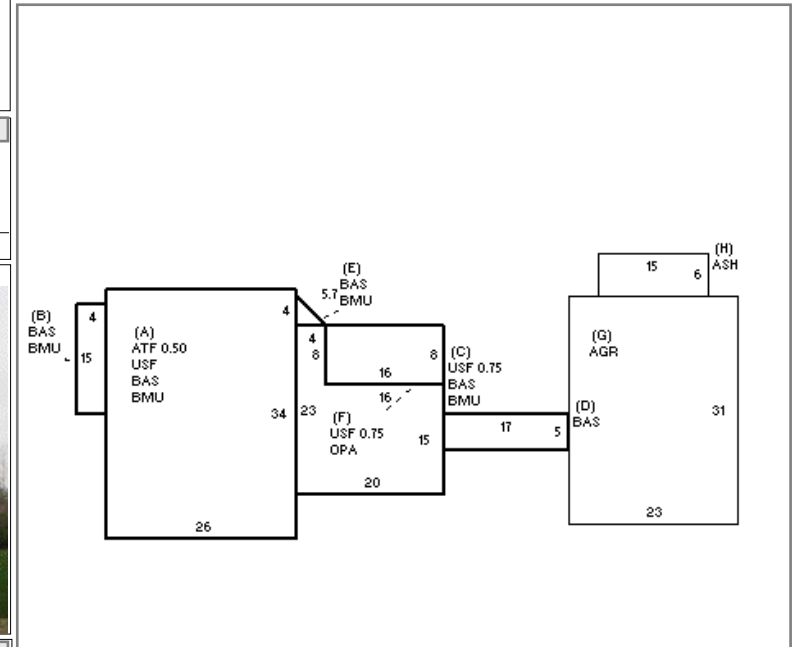

BUILDING	CD	ADJ	DESC	MEASURE	12/1/2020	NF
MODEL	1		RESIDENTIAL	LIST	4/8/2009	JH
STYLE	5	1.05	COLONIAL [100%]	REVIEW	1/11/2021	MR
QUALITY	V	1.65	VERY GOOD [100%]			
FRAME	1	1.00	WD FRAME [100%]			

BLDG COMMENTS
INFO @ DOOR (12/1/20)

YEAR BLT	2008	SIZE ADJ	0.990	ELEMENT	CD	DESCRIPTION	ADJ	S	BAT	T	DESCRIPTION	UNITS	YB	ADJ PRICE	RCN	TOTAL RCN	1,237,525		
NET AREA	2,598	DETAIL ADJ	1.000	FOUNDATION	4	FLR & WALL	1.00	+	BMU	N	BSMT UNFINISHED	1,284		95.86	123,089	CONDITION ELEM	CD		
\$NLA(RCN)	\$476	OVERALL	1.080	EXT COVER	1	WD SHINGLE	1.00	+	USF	L	UPPER STORY FIN	1,229	2008	297.86	366,074	EXTERIOR	A		
CAPACITY				ROOF SHAPE	1	GABLE	1.00	A	ATF	N	ATTIC FINISH	442		135.84	60,042	INTERIOR	A		
STORIES	2	1.00	ROOF COVER	1	ASPH/CMP SH	1.00	+	BAS	L	BASE AREA	1,369	2008	434.87	595,338	KITCHEN	A			
ROOMS	6	1.00	FLOOR COVER	1	HARDWOOD	1.00	F	OPA	N	OPEN PORCH	128		88.21	11,291	BATHS	A			
BEDROOMS	3	1.00	INT FINISH	1	PLASTER	1.00	G	AGR	N	ATT GARAGE	713		65.39	46,624	HEAT/ELEC	A			
BATHROOMS	2	1.00	HEATING/COOL	9	WARM/CL AIR	1.03	H	ASH	N	ATT SHED	90		49.36	4,442					
FIXTURES	9	\$20,849	FUEL SOURCE	2	GAS	1.00	GFP	O	GAS FIREPLACE	1			5,514.80	5,515					
GARAGE SPACES	2	1.00					ODS	O	OUTDOOR SHOWER	1			4,260.50	4,261					
% BSMT FIN	0	1.00																	
# 1/2 BATHS	1	1.00																	
# OF UNITS	1	1.00																	
																EFF.YR/AGE	2008 / 15		
																COND	13 13 %		
																FUNC	0		
																ECON	0		
																DEPR	13	% GD	87
																RCNLD	\$1,076,600		