

Key: 872

Town of BREWSTER - Fiscal Year 2025

9/17/2024 2:15 pm SEQ #: 903

LEGAL

LAND

DETACHED

BUILDING

CURRENT OWNER				PARCEL ID				LOCATION			
FELONEY LAWRENCE F JR & DENISE TRUSTEES FELONEY FAMILY LIVING TRUST 9 JAMESON STREET NATICK, MA 01760				79-136-0				74 SKIPPERS WAY			
TRANSFER HISTORY				DOS	T	SALE PRICE	BK-PG (Cert)				
FELONEY LAWRENCE F JR & D				02/15/2022	F	100	(229161)				
FELONEY LAWRENCE F JR				06/21/2004	A	1	(173415)				
FELONEY LAWRENCE F & THER				05/08/1959	XX		(23336)				

CLASS	CLASS%	DESCRIPTION			BN ID	BN	CARD	
1010	100	SINGLE FAMILY				1	1 of 1	
PMT NO	PMT DT	TY	DESC	AMOUNT	INSP	BY	1st	%
22	01/10/2018	7	ALTERATIONS	38,000	06/28/2019	NF	100	100
503	10/07/2010	1	NEW CONSTRUC	420,000	03/06/2012	MR	100	100
477	10/04/2010	6	DEMO	20,000	12/16/2010	JH	100	100
NP		12	CYCLICAL NON		10/15/2007	JH	100	100

CD	T	AC/SF/UN	Nbhd	St Ind	Infl	ADJ BASE	SAF	Topo	Lpi	VC	CREDIT AMT	ADJ VALUE	
100	S	5,850 6	1.00	A	1.00	A	1.00	964,480	6.58	A	1.00	BG- 4.40	851,670

TOTAL	5,850 SF	ZONING	RM	FRNT	0	ASSESSED	LAND 851,700 BUILDING 629,600 DETACHED 2,300 OTHER 0 TOTAL 1,483,600	CURRENT	803,500 601,600 2,300 0 1,407,400	PREVIOUS
Nbhd	NBHD 6	NOTE		LAND		ASSESSED		CURRENT		PREVIOUS
St Ind	AVERAGE	NOTE		LAND		ASSESSED		CURRENT		PREVIOUS
Infl	AVERAGE	NOTE		LAND		ASSESSED		CURRENT		PREVIOUS

TY	QUAL	COND	DIM/NOTE	YB	UNITS	ADJ PRICE	RCNLD
SHF	A	1.00	10 0.90 6X10		60	22.01	1,200
PTD	A	1.00	10 0.90 7X19		133	9.00	1,100



BLDG COMMENTS	BMF=FR/BR/BATH (EST PER PERMIT)
---------------	---------------------------------

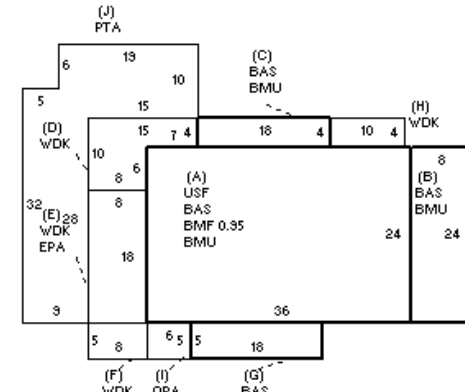

BUILDING	CD	ADJ	DESC	MEASURE	11/18/2020	NF
MODEL	1		RESIDENTIAL	LIST	12/16/2010	JH
STYLE	5	1.05	COLONIAL [100%]	REVIEW	1/8/2021	MR
QUALITY	+	1.10	PLUS AVE [100%]			
FRAME	1	1.00	WD FRAME [100%]			

YEAR BLT	2010	SIZE ADJ	1.000	ELEMENT	CD	DESCRIPTION	ADJ	S	BAT	T	DESCRIPTION	UNITS	YB	ADJ PRICE	RCN
NET AREA	2,082	DETAIL ADJ	1.000	FOUNDATION	4	FLR & WALL	1.00	+	BMU	N	BSMT UNFINISHED	1,128		67.08	75,664
\$NLA(RCN)	\$344	OVERALL	1.080	EXT COVER	1	WD SHINGLE	1.00	A	BMF	N	BSMT FINISH	821		42.29	34,723
				ROOF SHAPE	1	GABLE	1.00	A	USF	L	UPPER STORY FIN	864	2010	216.18	186,782
				ROOF COVER	1	ASPH/CMP SH	1.00	+	WDK	N	WOOD DECK	332		46.57	15,461
				FLOOR COVER	1	HARDWOOD	1.00	E	EPA	N	ENCLOSED PORCH	144		95.63	13,771
				INT FINISH	1	PLASTER	1.00	+	BAS	L	BASE AREA	1,218	2010	292.84	356,682
				HEATING/COOL	9	WARM/CL AIR	1.03	I	OPA	N	OPEN PORCH	30		59.40	1,782
				FUEL SOURCE	2	GAS	1.00	J	PTA	N	PATIO	462		15.11	6,982
									GFP	O	GAS FIREPLACE	1		3,713.70	3,714
									ODS	O	OUTDOOR SHOWER	1		2,869.00	2,869

TOTAL RCN	715,417
CONDITION ELEM	CD
EXTERIOR	A
INTERIOR	A
KITCHEN	A
BATHS	A
HEAT/ELEC	A
EFF.YR/AGE	2010 / 13
COND	12 12 %
FUNC	0
ECON	0
DEPR	12 % GD 88
RCNLD	\$629,600