

Key: 13053

Town of CHATHAM - Fiscal Year 2024

9/7/2023 9:38 am SEQ #: 8.920

LEG
AL
LAND

CURRENT OWNER				PARCEL ID				LOCATION				
SAVELY IV JAMES W & KRISTEN 44 SCATTEREE RD N CHATHAM, MA 02650				16J-7B-WA4				44 SCATTEREE RD				
TRANSFER HISTORY				DOS	T	SALE PRICE	BK-PG (Cert)					
SAVELY IV JAMES W & KRIST				07/08/2022	A		1 (230471)					
SAVELY IV JAMES W				06/02/2020	QS	1,375,000	(222607)					
WILSON FAMILY REVOCABLE T				06/12/2017	A		1 (213178)					
CD	T	AC/SF/UN	Nbhd	Inf1	Inf2	ADJ BASE	SAF	Inf3	Lpi	VC	CREDIT AMT	ADJ VALUE
100	S	30,834	NC	1.00	85 0.85	100 1.00	1,168,219	1.24	100	1.00	R12 3.75	1,023,150

CLASS	CLASS%	DESCRIPTION			BN ID	BN	CARD	
1010	100	SINGLE FAMILY				1	1 of 1	
PMT NO	PMT DT	TY	DESC	AMOUNT	INSP	BY	1st	%
20-350	12/23/2020	3	Renovations	80,600	04/06/2021	NF	100	100
13-032	10/08/2020	98	SALES QUESTI				100	100
SS14-24	01/18/2013	1	New Construc	515,000	03/12/2014	MR	100	100
12-597	01/01/2013	20	Splits/Land				100	100
	12/19/2012	9	Foundation	20,000	07/18/2013	SF	100	100

TOTAL	30,834 SF	ZONING	R40	FRNT	0	ASSESSED	CURRENT	PREVIOUS
Nbhd	NORTH CHATHAM	N O T E	INFL1=EASEMENT			LAND	1,023,200	852,600
Inf1	85		LAND	1,076,100	990,300			
Inf2	100		OTHER	0	0			
TOTAL						2,099,300	1,842,900	

TY	QUAL	COND	DIM/NOTE	YB	UNITS	ADJ PRICE	RCNLD

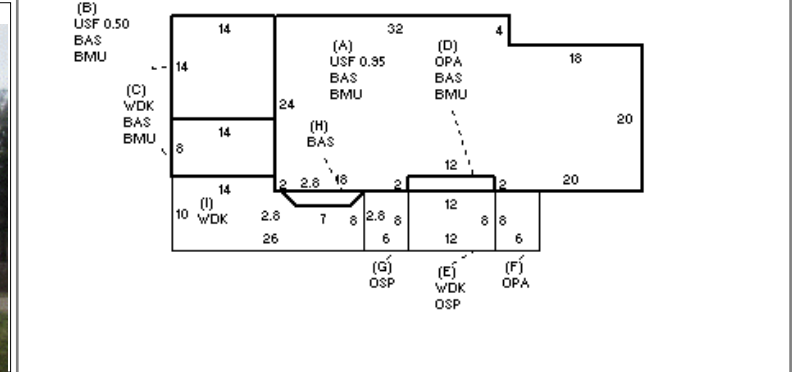

BUILDING	CD	ADJ	DESC	MEASURE	7/18/2013	SF
MODEL	1		RESIDENTIAL	LIST	7/18/2013	SF
STYLE	5	1.00	COLONIAL [100%]	REVIEW	6/10/2021	EMZ
QUALITY	G	1.55	GOOD [100%]			
FRAME	1	1.00	WOOD FRAME [100%]			

BLDG COMMENTS

YEAR BLT	2013	SIZE ADJ	1.000
NET AREA	2,601	DETAIL ADJ	1.030
\$NLA(RCN)	\$445	OVERALL	1.000
CAPACITY		UNITS	ADJ
STORIES		1.95	1.00
ROOMS		6	1.00
BEDROOMS		3	1.00
FULL BATHS		3	1.00
1/2 BATHS		1	1.00
FIXTURES		13	\$16,604
UNITS		1	1.00

ELEMENT	CD	DESCRIPTION	ADJ	S	BAT	T	DESCRIPTION	UNITS	YB	ADJ PRICE	RCN	TOTAL RCN	1,157,148
FOUNDATION	4	FLR & WALL	1.00	+	BMU	N	BSMT UNFINISHED	1,436		104.32	149,803		
EXT. COVER	1	WOOD SHINGLE	1.00	+	USF	L	UP-STRY FIN	1,147	2013	318.08	364,834		
ROOF SHAPE	3	GAMBREL	1.00	+	OSP	N	OPEN SCR PORCH	144		122.14	17,588		
ROOF COVER	1	ASPH/CMP SHIN	1.00	+	OPA	N	OPEN PORCH	72		117.95	8,493		
FLOOR COVER	1	HARDWOOD	1.00	+	BAS	L	BAS AREA	1,454	2013	374.85	545,039		
INT. FINISH	2	DRYWALL	1.00	+	WDK	N	WOOD DECK	426		90.52	38,561		
HEATING/COOL	9	WARM/COOL AIR	1.03		BMG	O	BSMT GARAGE	1		4,293.50	4,294		
FUEL SOURCE	2	GAS	1.00		GEN	O	GENERATOR	1		0.00			
					GFP	O	GAS LOG/FP/E FP	1		9,644.10	9,644		
					ODS	O	OUT DOOR SHWR-A	1		2,289.40	2,289		

CONDITION ELEM	CD
EXTERIOR	A
INTERIOR	G
KITCHEN	A
BATHS	A
HEAT	A
ELECT	A

EFF. YR/AGE	2015 / 7
COND	7 7 %
FUNC	0
ECON	0
DEPR	7 % GD 93

RCNLD \$1,076,100