

Key: 1440

Town of CHATHAM - Fiscal Year 2024

9/7/2023 9:38 am SEQ #: 1.573

LEGAL

LAND

CURRENT OWNER				PARCEL ID				LOCATION			
MCKEON FAMILY LIVING TRUST				12L-1-14				12 EASY ST			
MCKEON BRIAN M & ANNA M TRSTES				TRANSFER HISTORY				DOS	T	SALE PRICE	BK-PG (Cert)
64 HANCOCK ST				MCKEON FAMILY LIVING TRUS				04/11/2019	A	10	31946-112
LEXINGTON, MA 02420-3421				MCKEON BRIAN & ANNA M				03/07/2011	A	1	25302-277
				FRANKLIN S PEASE JR TRUST				02/25/2008	A	1	22694-49

CLASS	CLASS%	DESCRIPTION			BN ID	BN	CARD	
1010	100	SINGLE FAMILY				1	1 of 1	
PMT NO	PMT DT	TY	DESC	AMOUNT	INSP	BY	1st	%
19-805	11/12/2019	3	Renovations	186,030	04/09/2021	NF	100	100
95-336	04/06/2007	50	Meas & List			RRC	100	100
95-305	10/10/1995	2	Additions	225,000			100	100
95-307	08/01/1995	5	Demolitions	1,000			100	100
	08/01/1995	1	New Construc	6,000			100	100

CD	T	AC/SF/UN	Nbhd	Inf1	Inf2	ADJ BASE	SAF	Inf3	Lpi	VC	CREDIT AMT	ADJ VALUE
100	S	15,246	NC	1.00	100	1,759,200	2.23	100	1.00	CV4	4.80	1,375,640

TOTAL	15,246 SF	ZONING	R40	FRNT	277	ASSESSED	CURRENT	PREVIOUS
Nbhd	NORTH CHATHAM	N O T E	Wv. RIGHT TO USE PRIVATE BEACH FOR SUNBATHING			LAND	1,375,600	1,146,300
Inf1	100		BUILDING	1,160,200	1,053,400			
Inf2	100		DETACHED	0	0			
			OTHER	0	0			
TOTAL						2,535,800	2,199,700	

TY	QUAL	COND	DIM/NOTE	YB	UNITS	ADJ PRICE	RCNLD



BLDG COMMENTS
4/9/21 INFO @ DOOR-NF

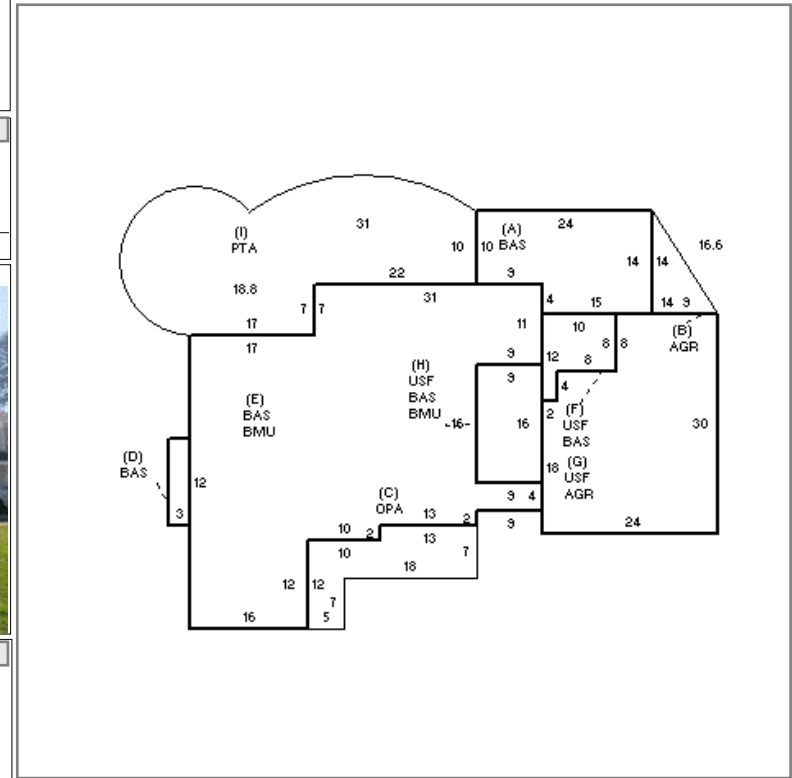

DETACHED

BUILDING

BUILDING	CD	ADJ	DESC	MEASURE
MODEL	1		RESIDENTIAL	LIST
STYLE	3	0.80	SPLIT LEVEL [100%]	REVIEW
QUALITY	G	1.55	GOOD [100%]	6/16/2021
FRAME	1	1.00	WOOD FRAME [100%]	EMZ

YEAR BLT	1995	SIZE ADJ	1.000	ELEMENT	CD	DESCRIPTION	ADJ	S	BAT	T	DESCRIPTION	UNITS	YB	ADJ PRICE	RCN
NET AREA	2,979	DETAIL ADJ	0.824	FOUNDATION	4	FLR & WALL	1.00	+	BAS	L	BAS AREA	2,115	1995	294.41	622,674
\$NLA(RCN)	\$389	OVERALL	1.000	EXT. COVER	1	WOOD SHINGLE	1.00	+	AGR	N	ATTACHED GARAGE	695		117.59	81,724
				ROOF SHAPE	1	GABLE	1.00	C	OPA	N	OPEN PORCH	176		117.96	20,761
				ROOF COVER	1	ASPH/CMP SHIN	1.00	+	BMU	N	BSMT UNFINISHED	1,691		101.62	171,844
				FLOOR COVER	13	HARDWD/CARPET	1.00	+	USF	L	UP-STRY FIN	864	1995	249.82	215,841
				INT. FINISH	2	DRYWALL	1.00	I	PTA	N	PATIO/STOOP	785		27.75	21,781
				HEATING/COOL	9	WARM/COOL AIR	1.03	F11	O	FPL 1S 1OP	1		11,589.40	11,589	
				FUEL SOURCE	2	GAS	1.00	KIT	O	EXTRA KITCHEN	1		2,526.50	2,527	
								ODS	O	OUT DOOR SHWR-A	1		2,289.40	2,289	

TOTAL RCN	1,160,225
CONDITION ELEM CD	
EXTERIOR	V
INTERIOR	V
KITCHEN	V
BATHS	V
HEAT	U
ELECT	U
EFF.YR/AGE 2022 / 0	
COND	0 0 %
FUNC	0
ECON	0
DEPR	0 % GD 100
RCNLD	\$1,160,200