

Key: 1455

Town of CHATHAM - Fiscal Year 2024

9/7/2023 9:38 am SEQ #: 1.588

LEGAL

LAND

DETACHED

BUILDING

| CURRENT OWNER | | PARCEL ID | | LOCATION | |
|---|--|------------|----|-----------------|--------------|
| GALE BRADLEY T & JANE E 114 MOORINGS PARK DR A 510 NAPLES, FL 34105 | | 12L-2-12 | | 771 FOX HILL RD | |
| TRANSFER HISTORY | | DOS | T | SALE PRICE | BK-PG (Cert) |
| GALE BRADLEY T & JANE E LARSON | | 04/30/1999 | QS | 1,000,000 | 12239-251 |
| | | 07/16/1949 | N | | 1 725-154 |

| CLASS | CLASS% | DESCRIPTION | | BN ID | BN | CARD | |
|--------|------------|---------------|--------------|-----------|------------|--------|---------|
| 1010 | 100 | SINGLE FAMILY | | | 1 | 1 of 1 | |
| PMT NO | PMT DT | TY | DESC | AMOUNT | INSP | BY | 1st % |
| 22-015 | 01/06/2022 | 3 | Renovations | 118,000 | 03/07/2023 | NF | 100 100 |
| 12-212 | 04/26/2012 | 3 | Renovations | 30,000 | 07/22/2013 | SF | 100 100 |
| 12-169 | 04/02/2012 | 1 | New Construc | 15,000 | 07/22/2013 | SF | 100 100 |
| 11-493 | 12/06/2011 | 1 | New Construc | 1,000,000 | 05/02/2012 | MR | 100 100 |
| 11-494 | 12/01/2011 | 5 | Demolitions | 25,000 | 05/02/2012 | MR | 100 100 |

| CD | T | AC/SF/UN | Nbhd | Inf1 | Inf2 | ADJ BASE | SAF | Inf3 | Lpi | VC | CREDIT AMT | ADJ VALUE |
|-----|---|----------|------|------|------|----------|-----|------|-----|-------|------------|-----------|
| 100 | S | 40,000 | NC | 1.00 | 100 | 1.00 | 100 | 1.00 | OF6 | 11.00 | | 3,702,020 |
| 300 | A | 0.341 | NC | 1.00 | 100 | 1.00 | 100 | 1.00 | OF6 | 11.00 | | 72,020 |

| TOTAL | 1.259 Acres | ZONING | R40 | FRNT | 0 | ASSESSED | CURRENT | PREVIOUS |
|-------|---------------|------------------------------|--------------|------------------|------------------|----------|---------|----------|
| Nbhd | NORTH CHATHAM | NOTE Bay Frt/lots 12 & 13 | LAND | 3,774,000 | 3,144,900 | | | |
| Inf1 | 100 | | BUILDING | 1,688,500 | 1,504,700 | | | |
| Inf2 | 100 | | DETACHED | 0 | 0 | | | |
| | | | OTHER | 0 | 0 | | | |
| | | | TOTAL | 5,462,500 | 4,649,600 | | | |

| TY | QUAL | COND | DIM/NOTE | YB | UNITS | ADJ PRICE | RCNLD |
|----|------|------|----------|----|-------|-----------|-------|
| | | | | | | | |



BLDG COMMENTS
LLF= FAM RM, OFFICE, BATH
INFO @ DOOR 3/7/2023

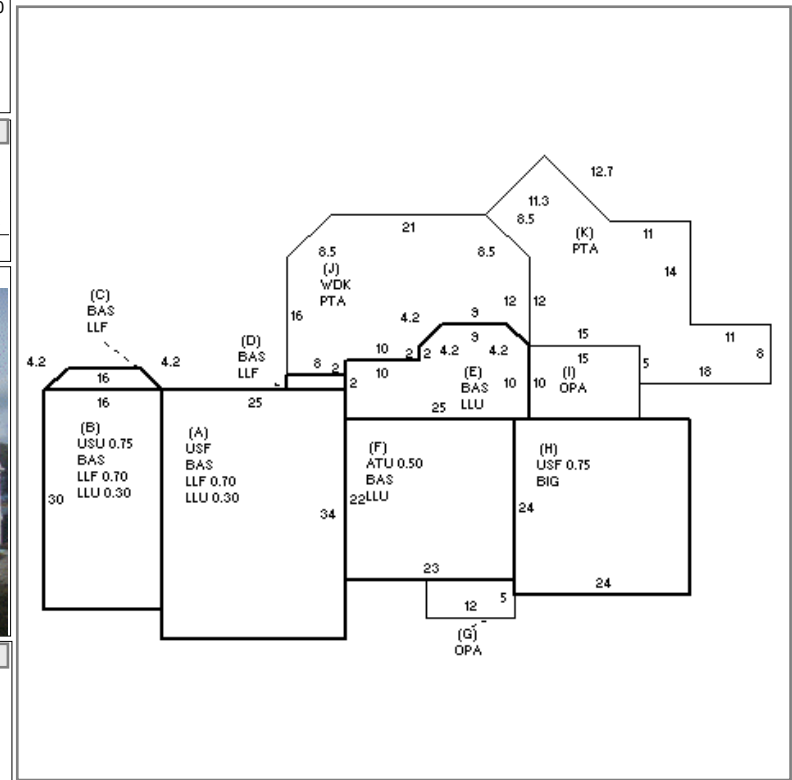

| BUILDING | CD | ADJ | DESC | MEASURE | | |
|----------|----|------|-------------------|---------|-----------|-----|
| MODEL | 1 | | RESIDENTIAL | LIST | 3/7/2023 | EST |
| STYLE | 4 | 1.00 | CAPE [100%] | REVIEW | 3/22/2023 | EMZ |
| QUALITY | G | 1.55 | GOOD [100%] | | | |
| FRAME | 1 | 1.00 | WOOD FRAME [100%] | | | |

| YEAR BLT | 2011 | SIZE ADJ | 1.000 | ELEMENT | CD | DESCRIPTION | ADJ | S | BAT | T | DESCRIPTION | UNITS | YB | ADJ PRICE | RCN | TOTAL RCN | 1,897,231 | |
|------------|-------|------------|--------------|------------|---------------|--------------|-------|------|-----------------|-----------------|----------------|-------------|----------|-----------|------------|----------------|-----------|---|
| NET AREA | 3,439 | DETAIL ADJ | 1.030 | FOUNDATION | 4 | FLR & WALL | 1.00 | + | LLU | N | LOWER LEVEL UN | 1,171 | | 194.42 | 227,667 | CONDITION ELEM | CD | |
| \$NLA(RCN) | \$552 | OVERALL | 1.000 | EXT. COVER | 1 | WOOD SHINGLE | 1.00 | + | BAS | L | BAS AREA | 2,157 | 2011 | 345.06 | 744,295 | EXTERIOR | A | |
| CAPACITY | | | UNITS | ADJ | ROOF SHAPE | 1 | GABLE | 1.00 | + | USF | L | UP-STRY FIN | 1,282 | 2011 | 292.80 | 375,364 | INTERIOR | A |
| STORIES | 1.75 | 1.00 | ROOF COVER | 1 | ASPH/CMP SHIN | 1.00 | B | USU | N | UPPER STORY UNF | 360 | | 175.81 | 63,293 | KITCHEN | A | | |
| ROOMS | 8 | 1.00 | FLOOR COVER | 1 | HARDWOOD | 1.00 | + | LLF | N | LOWER LEVEL FIN | 986 | | 253.94 | 250,382 | BATHS | A | | |
| BEDROOMS | 3 | 1.00 | INT. FINISH | 2 | DRYWALL | 1.00 | F | ATU | N | UNFIN ATTIC | 253 | | 121.68 | 30,785 | HEAT | A | | |
| FULL BATHS | 4 | 1.00 | HEATING/COOL | 9 | WARM/COOL AIR | 1.03 | + | OPA | N | OPEN PORCH | 210 | | 117.96 | 24,771 | ELECT | A | | |
| 1/2 BATHS | 1 | 1.00 | FUEL SOURCE | 2 | GAS | 1.00 | H | BIG | N | BUILT-IN GARAGE | 576 | | 119.61 | 68,896 | | | | |
| FIXTURES | 14 | \$17,881 | | | | | + | PTA | N | PATIO/STOOP | 1,164 | | 27.75 | 32,296 | | | | |
| UNITS | 1 | 1.00 | | | | | J | WDK | N | WOOD DECK | 574 | | 90.52 | 51,959 | EFF.YR/AGE | 2011 / 11 | | |
| | | | | | | | GFP | O | GAS LOG/FP/E FP | 1 | | | 9,644.10 | 9,644 | COND | 11 11 % | | |
| | | | | | | | | | | | | | | | FUNC | 0 | | |
| | | | | | | | | | | | | | | | ECON | 0 | | |
| | | | | | | | | | | | | | | | DEPR | 11 % GD 89 | | |
| | | | | | | | | | | | | | | | RCNLD | \$1,688,500 | | |