

Key: 1530

Town of CHATHAM - Fiscal Year 2024

9/7/2023 9:38 am SEQ #: 1.668

LEGAL

CURRENT OWNER				PARCEL ID				LOCATION			
B & G CONTE REALTY TRUST CONTE BIAGIO A & GLORIA TRUSTEES 78 WINCH ST FRAMINGHAM, MA 01701				13A1-3-D46				235 STAGE ISLAND RD			
TRANSFER HISTORY				DOS	T	SALE PRICE		BK-PG (Cert)			
B & G CONTE REALTY TRUST				06/03/2002	A	100 (165460)					
N/A				06/17/1985	QS	287,000 (102057)					

CLASS	CLASS%	DESCRIPTION			BN ID	BN	CARD	
1010	100	SINGLE FAMILY				1	1 of 1	
PMT NO	PMT DT	TY	DESC	AMOUNT	INSP	BY	1st	%
1984140	04/16/2007 07/12/1984	50 99	Meas & List n/a			RRC	100 100	100 100

LAND

CD	T	AC/SF/UN	Nbhd	Inf1	Inf2	ADJ BASE	SAF	Inf3	Lpi	VC	CREDIT AMT	ADJ VALUE
100	S	40,000	MOR	1.00	100	1.00	100	1.00	R13	3.20		1,076,950
300	A	0.041	MOR	1.00	100	1.00	100	1.00	R13	3.20		2,520

TOTAL	41,780 SF	ZONING	R40	FRNT	0	ASSESSED	CURRENT	PREVIOUS
Nbhd	MORRIS ISLAND	NOTE	LAND		1,079,500	899,500		
Inf1	100		BUILDING		648,900	590,500		
Inf2	100		DETACHED		0	0		
			OTHER		0	0		
TOTAL					1,728,400	1,490,000		

DETACHED

TY	QUAL	COND	DIM/NOTE	YB	UNITS	ADJ PRICE	RCNLD

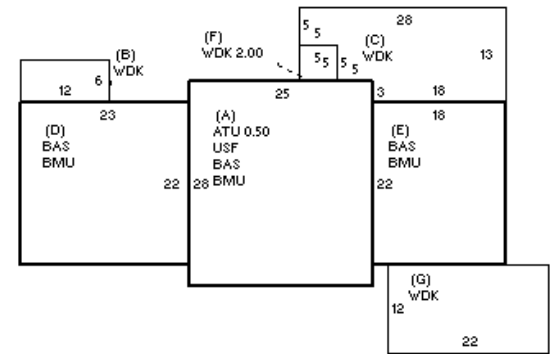

BUILDING	CD	ADJ	DESC	MEASURE	REVIEW
MODEL	1		RESIDENTIAL		
STYLE	5	1.00	COLONIAL [100%]	LIST	
QUALITY	+	1.20	PLUS AVE [100%]	REVIEW	1/21/2013 MR
FRAME	1	1.00	WOOD FRAME [100%]		

BUILDING

YEAR BLT	1985	SIZE ADJ	1.000	ELEMENT	CD	DESCRIPTION	ADJ	S	BAT	T	DESCRIPTION	UNITS	YB	ADJ PRICE	RCN	TOTAL RCN	876,955	
NET AREA	2,302	DETAIL ADJ	1.010	FOUNDATION	4	FLR & WALL	1.00	+	BMU	N	BSMT UNFINISHED	1,602		79.34	127,109	CONDITION ELEM	CD	
\$NLA(RCN)	\$381	OVERALL	1.000	EXT. COVER	2	CLAPBOARD	1.00	+	BAS	L	BAS AREA	1,602	1985	289.77	464,214	EXTERIOR		
				ROOF SHAPE	1	GABLE	1.00	A	USF	L	UP-STRY FIN	700	1985	245.88	172,117	INTERIOR		
				ROOF COVER	2	WOOD SHIN	1.01	A	ATU	N	UNFIN ATTIC	350		94.20	32,970	KITCHEN		
				FLOOR COVER	16	HARDWD/OTHER	1.00	+	WDK	N	WOOD DECK	695		70.08	48,706	BATHS		
				INT. FINISH	2	DRYWALL	1.00		BMG	O	BSMT GARAGE	2		3,323.40	6,647	HEAT		
				HEATING/COOL	5	ELECTRIC BB	1.00		F22	O	FPL 2S 2OP	1		17,436.00	17,436	ELECT		
				FUEL SOURCE	1	OIL	1.00											
CAPACITY		UNITS	ADJ															
STORIES		2.5	1.00															
ROOMS		0	1.00															
BEDROOMS		3	1.00															
FULL BATHS		2	1.00															
1/2 BATHS		1	1.00															
FIXTURES		8	\$7,757															
UNITS		1	1.00															
EFF.YR/AGE		1985 / 37																
COND	26		26 %															
FUNC	0																	
ECON	0																	
DEPR	26	% GD	74															
RCNLD				\$648,900														