

Key: 1539

Town of CHATHAM - Fiscal Year 2024

9/7/2023 9:38 am SEQ #: 1.676

LEGALS AND

CURRENT OWNER				PARCEL ID				LOCATION			
ENHORNING MARGUERITE c/o MODINE JR DAVID W 371 OAK AVE CHESHIRE, CT 06410				13A1-8-D128				182 STAGE ISLAND RD			
TRANSFER HISTORY				DOS	T	SALE PRICE	BK-PG (Cert)				
ENHORNING MARGUERITE				12/16/1992	L	380,000	(128723)				
SEQUIN ROBERT M				07/28/1988	A	1,340,000	(114950)				
CAPE VENTURES LIMITED REA				12/01/1986	L	583,500	(109265)				

CLASS	CLASS%	DESCRIPTION			BN ID	BN	CARD	
1010	100	SINGLE FAMILY				1	1 of 1	
PMT NO	PMT DT	TY	DESC	AMOUNT	INSP	BY	1st	%
14-769	12/12/2014	3	Renovations	95,000	06/06/2016	WFF	100	100
	03/18/2010	51	Meas			CE	100	100
09-017	11/16/2009	3	Renovations	59,000	04/18/2012	MR	100	100
	03/24/2008	50	Meas & List			RRC	100	100
07-006	01/04/2007	2	Additions	50,000	03/24/2008		100	100

CD	T	AC/SF/UN	Nbhd	Inf1	Inf2	ADJ BASE	SAF	Inf3	Lpi	VC	CREDIT AMT	ADJ VALUE
100	S	39,602	MOR	1.00	100	1.00	100	1.00	CF4	9.50		3,190,390

TOTAL	39,602 SF	ZONING	R40	FRNT	0	ASSESSED	CURRENT	PREVIOUS
Nbhd	MORRIS ISLAND	NOTE	Harbor Frt			LAND	3,190,400	2,658,500
Inf1	100		BUILDING	2,380,600	2,128,800			
Inf2	100		DETACHED	159,300	157,400			
			OTHER	0	0			
			TOTAL	5,730,300	4,944,700			

DETAILED

TY	QUAL	COND	DIM/NOTE	YB	UNITS	ADJ PRICE	RCNLD	
IPV	G	1.20	10 0.90	12X32	1988	384	42.09	14,500
PTD	G	1.20	10 0.90		2007	400	13.56	4,900
DCK	+	1.10	10 0.90		2007	432	336.55	130,800
STR	V	1.50	10 0.90		2007	224	45.00	9,100



BLDG COMMENTS  
LLF=1RM,2BDRM,1F.BATH

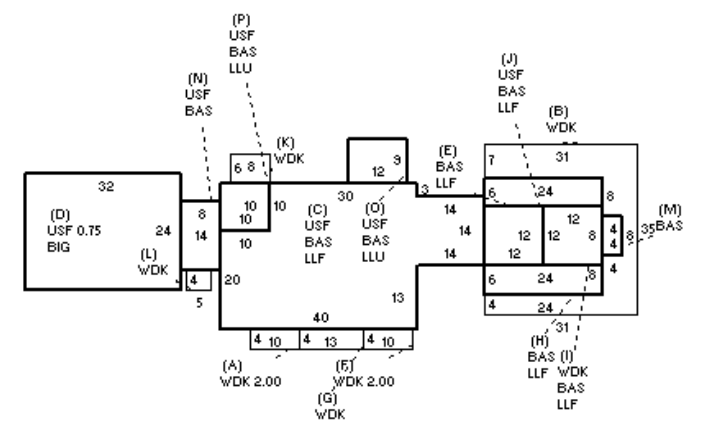

BUILDING

BUILDING	CD	ADJ	DESC	MEASURE		
MODEL	1		RESIDENTIAL	LIST	3/6/2017	APK
STYLE	8	0.95	CONTEMPORARY [100%]			
QUALITY	G	1.68	GOOD [84%]			
FRAME	1	1.00	WOOD FRAME [100%]			

YEAR BLT	1987	SIZE ADJ	1.000	ELEMENT	CD	DESCRIPTION	ADJ
NET AREA	4,560	DETAIL ADJ	1.007	FOUNDATION	4	FLR & WALL	1.00
\$NLA(RCN)	\$522	OVERALL	1.000	EXT. COVER	1	WOOD SHINGLE	1.00
CAPACITY				ROOF SHAPE	1	GABLE	1.00
STORIES	2	ADJ	1.00	ROOF COVER	2	WOOD SHIN	1.01
ROOMS	0		1.00	FLOOR COVER	1	HARDWOOD	1.00
BEDROOMS	4		1.00	INT. FINISH	2	DRYWALL	1.00
FULL BATHS	3		1.00	HEATING/COOL	11	HT-WT/COOL AIR	1.05
1/2 BATHS	2		1.00	FUEL SOURCE	1	OIL	1.00
FIXTURES	20	\$27,100					
UNITS	1	1.00					

S	BAT	T	DESCRIPTION	UNITS	YB	ADJ PRICE	RCN
+	WDK	N	WOOD DECK	901		98.23	88,504
+	LLF	N	LOWER LEVEL FIN	1,872		267.52	500,805
+	USF	L	UP-STRY FIN	2,084	1987	308.46	642,830
D	BIG	N	BUILT-IN GARAGE	768		126.58	97,213
J	USF	L	UP-STRY FIN	144	2009	308.46	44,418
+	BAS	L	BAS AREA	608	2009	363.52	221,022
+	BAS	L	BAS AREA	1,508	1987	363.52	548,191
+	LLU	N	LOWER LEVEL UN	208		204.82	42,603
O	BAS	L	BAS AREA	108	2008	363.51	39,260
O	USF	L	UP-STRY FIN	108	2008	308.46	33,314
F32	O		FPL 3S 2OP	2		40,525.25	81,051
HTB	O		HOT TUB-ADD	1		11,800.90	11,801
ODS	O		OUT DOOR SHWR-A	1		2,484.30	2,484

TOTAL RCN	2,380,595
CONDITION ELEM	CD
EXTERIOR	V
INTERIOR	V
KITCHEN	V
BATHS	V
HEAT	U
ELECT	U
EFF.YR/AGE	2022 / 0
COND	0 0 %
FUNC	0
ECON	0
DEPR	0 % GD 100
RCNLD	\$2,380,600