

Key: 1982

Town of CHATHAM - Fiscal Year 2024

9/7/2023 9:38 am SEQ #: 2.148

LEGAL

CURRENT OWNER				PARCEL ID				LOCATION			
LIFESTYLE CAPE COD 1 LLC 155 E BOARDWALK DR STE 473 FT COLLINS, CO 80525				13J-11-AR12A				73 ROWLAND DR			
TRANSFER HISTORY				DOS	T	SALE PRICE	BK-PG (Cert)				
LIFESTYLE CAPE COD 1 LLC				04/03/2020	A	1	32806-238				
MARK WILLIAM JOHNSON 2010				04/15/2016	C	1,267,500	29584-81				
BAILEY TIMOTHY P & CATHER				09/10/2004	QS	900,000	19022-162				

CLASS	CLASS%	DESCRIPTION			BN ID	BN	CARD	
1010	100	SINGLE FAMILY				1	1 of 1	
PMT NO	PMT DT	TY	DESC	AMOUNT	INSP	BY	1st	%
17-552	08/23/2017	3	Renovations	9,200	07/20/2018	NF	100	100
17-419	06/27/2017	3	Renovations		07/20/2018	NF	100	100
17-126	02/28/2017	1	New Construc	500,000	01/30/2019	TCK	100	100
	06/29/2016	98	SALES QUESTI				0	0
	03/17/2006	50	Meas & List			RRC	100	100

LAND

CD	T	AC/SF/UN	Nbhd	Inf1	Inf2	ADJ BASE	SAF	Inf3	Lpi	VC	CREDIT AMT	ADJ VALUE
100	S	34,682	NC	1.00	1.00	1,282,750	1.12	100	1.00	CF1	3.50	1,147,140

TOTAL	34,682 SF	ZONING	R40	FRNT	0	ASSESSED	CURRENT	PREVIOUS
Nbhd	NORTH CHATHAM	NOTE				LAND	1,147,100	955,900
Inf1	100		LAND	2,002,300	1,670,900			
Inf2	100		DETACHED	1,200	1,200			
			OTHER	0	0			
		TOTAL	3,150,600	2,628,000				

DETACHED

TY	QUAL	COND	DIM/NOTE	YB	UNITS	ADJ PRICE	RCNLD
SHF	A	1.00	10 0.90 12X8	2005	96	14.26	1,200

TY	QUAL	COND	DIM/NOTE	YB	UNITS	ADJ PRICE	RCNLD
SHF	A	1.00	10 0.90 12X8	2005	96	14.26	1,200



BLDG COMMENTS
BMF=2RMS, 1FBATH

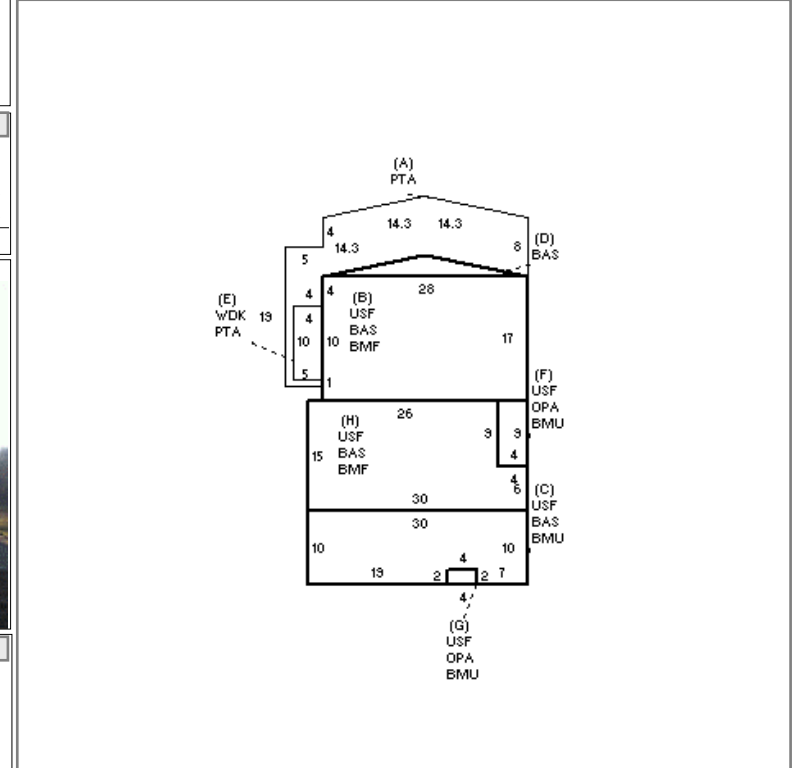

BUILDING

BUILDING	CD	ADJ	DESC	MEASURE	1/30/2019	TCK
MODEL	1		RESIDENTIAL	LIST	7/6/2021	MLS
STYLE	19	1.30	NEW STYLE [100%]	REVIEW	7/6/2021	APK
QUALITY	V	2.35	VERY GOOD [100%]			
FRAME	1	1.00	WOOD FRAME [100%]			

G

YEAR BLT	2017	SIZE ADJ	1.000	ELEMENT	CD	DESCRIPTION	ADJ	S	BAT	T	DESCRIPTION	UNITS	YB	ADJ PRICE	RCN	TOTAL RCN	2,107,729
NET AREA	2,450	DETAIL ADJ	1.352	FOUNDATION	4	FLR & WALL	1.00	+	PTA	N	PATIO/STOOP	319		42.06	13,419	CONDITION ELEM	CD
\$NLA(RCN)	\$860	OVERALL	1.000	EXT. COVER	1	WOOD SHINGLE	1.00	+	BMF	N	BSMT FINISH-SEP	890		255.21	227,137	EXTERIOR	A
				ROOF SHAPE	1	GABLE	1.00	+	USF	L	UP-STRY FIN	1,226	2017	638.44	782,733	INTERIOR	A
				ROOF COVER	2	WOOD SHIN	1.01	+	BMU	N	BSMT UNFINISHED	336		212.63	71,442	KITCHEN	A
				FLOOR COVER	1	HARDWOOD	1.00	+	BAS	L	BAS AREA	1,224	2017	752.41	920,951	BATHS	A
				INT. FINISH	2	DRYWALL	1.00	E	WDK	N	WOOD DECK	40		137.24	5,490	HEAT	A
				HEATING/COOL	9	WARM/COOL AIR	1.03	+	OPA	N	OPEN PORCH	44		178.81	7,868	ELECT	A
				FUEL SOURCE	2	GAS	1.00		F21	O	FPL 2S 1OP	1		24,383.60	24,384		
									ODS	O	OUT DOOR SHWR-A	1		3,471.00	3,471		

CAPACITY	UNITS	ADJ
STORIES	2	1.00
ROOMS	8	1.00
BEDROOMS	4	1.00
FULL BATHS	5	1.00
1/2 BATHS	1	1.00
FIXTURES	20	\$50,835
UNITS	1	1.00

EFF. YR/AGE	2017 / 5
COND	5 5 %
FUNC	0
ECON	0
DEPR	5 % GD 95

RCNLD	\$2,002,300
-------	-------------