

Key: 2039

Town of CHATHAM - Fiscal Year 2024

9/7/2023 9:38 am SEQ #: 2.205

LEGAL

LAND

DETACHED

BUILDING

CURRENT OWNER				PARCEL ID				LOCATION			
151 LANDING LANE NOMINEE REALTY TRUST SEMPLER BRIAN S & LAURA H TRSTES 65 BAY STATE AVE #2 SOMERVILLE, MA 02144				13K-27-R9				151 LANDING LN			
TRANSFER HISTORY				DOS	T	SALE PRICE	BK-PG (Cert)				
151 LANDING LANE NOMINEE				04/24/2018	A	1	31219-150				
SEMPLER BRIAN S & LAURA H				04/08/2016	QS	1,350,000	29567-116				
KELLAWAY KENDALL JR & SUS				11/05/2013	H	1,142,000	27806-71				

CLASS	CLASS%	DESCRIPTION			BN ID	BN	CARD	
1010	100	SINGLE FAMILY				1	1 of 1	
PMT NO	PMT DT	TY	DESC	AMOUNT	INSP	BY	1st	%
21-455	05/04/2021	13	SH.MTL/FHAIR	37,777	04/14/2022	NF	100	100
21-349	04/07/2021	77	SOLAR PANELS	13,500			100	100
20-0567	10/01/2020	1	New Construc	875,500	03/07/2023	NF	100	100
19-047	07/11/2019	75	SPECIAL PERM		04/07/2021	NF	100	100
	07/26/2016	98	SALES QUESTI				100	100

CD	T	AC/SF/UN	Nbhd	Infl1	Infl2	ADJ BASE	SAF	Infl3	Lpi	VC	CREDIT AMT	ADJ VALUE
100	S	20,770	NC	1.00	95 0.95	100 1.00	1,810,510	1.72	100 1.00	CF4	5.20	1,484,920

TOTAL	20,770 SF	ZONING	R40	FRNT	0	ASSESSED	CURRENT	PREVIOUS
Nbhd	NORTH CHATHAM	N	Ex Wv Bulkhead=92, RYDERS COVE			LAND	1,484,900	1,237,400
Infl1	95	O	ASSOC.=DOCK,POOL,TENNIS COURTS INFL2=TOPO.			BUILDING	1,820,900	1,532,700
Infl2	100	T	EASMENT TO USE MAINTAIN SEA WALL BK27806/66			DETACHED	4,700	4,500
		E				OTHER	0	0
						TOTAL	3,310,500	2,774,600

TY	QUAL	COND	DIM/NOTE	YB	UNITS	ADJ PRICE	RCNLD
STR	A	1.00	30 0.70	3X75	225	30.00	4,700



BLDG COMMENTS	LLF=2 ROOMS/HALF BATH
---------------	-----------------------

BUILDING	CD	ADJ	DESC	MEASURE	4/7/2021	NF
MODEL	1		RESIDENTIAL	LIST	4/7/2021	EST
STYLE	19	1.30	NEW STYLE [100%]	REVIEW	3/22/2023	EMZ
QUALITY	G	1.55	GOOD [100%]			
FRAME	1	1.00	WOOD FRAME [100%]			

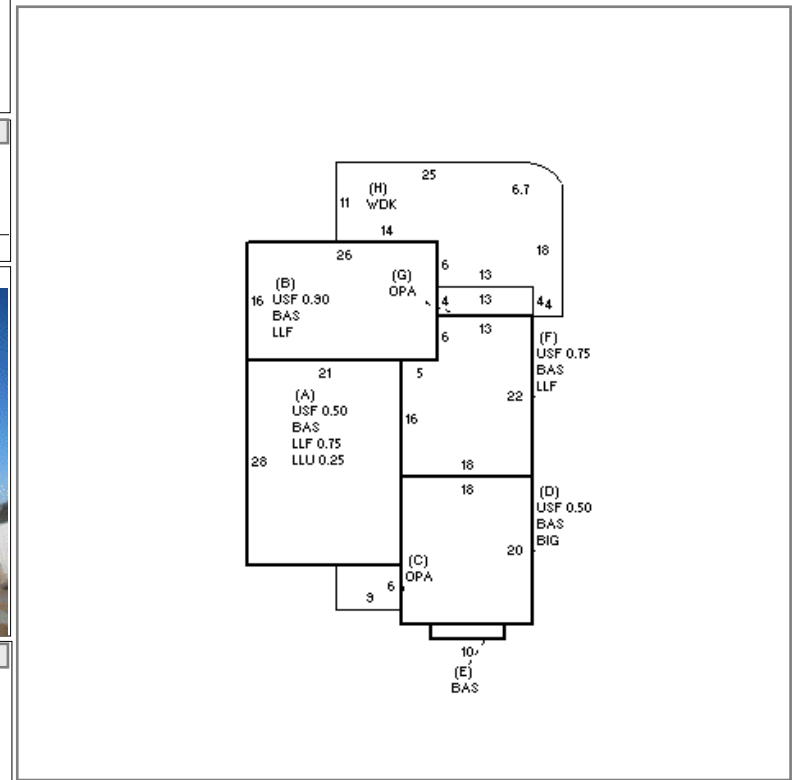

YEAR BLT	2020	SIZE ADJ	1.000	ELEMENT	CD	DESCRIPTION	ADJ	S	BAT	T	DESCRIPTION	UNITS	YB	ADJ PRICE	RCN	TOTAL RCN	1,858,021
NET AREA	2,873	DETAIL ADJ	1.339	FOUNDATION	4	FLR & WALL	1.00	A	LLU	N	LOWER LEVEL UN	147		259.54	38,152	CONDITION ELEM CD	
\$NLA(RCN)	\$647	OVERALL	1.000	EXT. COVER	1	WOOD SHINGLE	1.00	+	USF	L	UP-STRY FIN	1,123	2020	390.85	438,923	EXTERIOR	A
				ROOF SHAPE	1	GABLE	1.00	+	LLF	N	LOWER LEVEL FIN	1,223		338.98	414,571	INTERIOR	A
				ROOF COVER	1	ASPH/CMP SHIN	1.00	+	OPA	N	OPEN PORCH	106		117.96	12,504	KITCHEN	A
				FLOOR COVER	1	HARDWOOD	1.00	D	BIG	N	BUILT-IN GARAGE	360		126.62	45,584	BATHS	A
				INT. FINISH	2	DRYWALL	1.00	+	BAS	L	BAS AREA	1,750	2020	460.62	806,081	HEAT	A
				HEATING/COOL	9	WARM/COOL AIR	1.03	H	WDK	N	WOOD DECK	455		90.52	41,187	ELECT	A
				FUEL SOURCE	2	GAS	1.00	F22	O	FPL 2S 2OP	1		22,521.50	22,522			
								GFP	O	GAS LOG/FP/E FP	1		9,644.10	9,644			
								ODS	O	OUT DOOR SHWR-A	1		2,289.40	2,289			
												EFF.YR/AGE	2020 / 2				
												COND	2 2 %				
												FUNC	0				
												ECON	0				
												DEPR	2 % GD		98		
												RCNLD			\$1,820,900		