

Key: 2051

Town of CHATHAM - Fiscal Year 2024

9/7/2023 9:38 am SEQ #: 2.218

LEGAL LAND

Table with columns: CURRENT OWNER, PARCEL ID, LOCATION, TRANSFER HISTORY, and various financial/property metrics.

Table with columns: CLASS, CLASS%, DESCRIPTION, BN ID, BN, CARD, and detailed transaction history.

LAND

Table with columns: TOTAL, ZONING, FRNT, ASSESSED, CURRENT, PREVIOUS, and property details.

DETACHED

Table with columns: TY, QUAL, COND, DIM/NOTE, YB, UNITS, ADJ PRICE, RCNLD, and photo information.

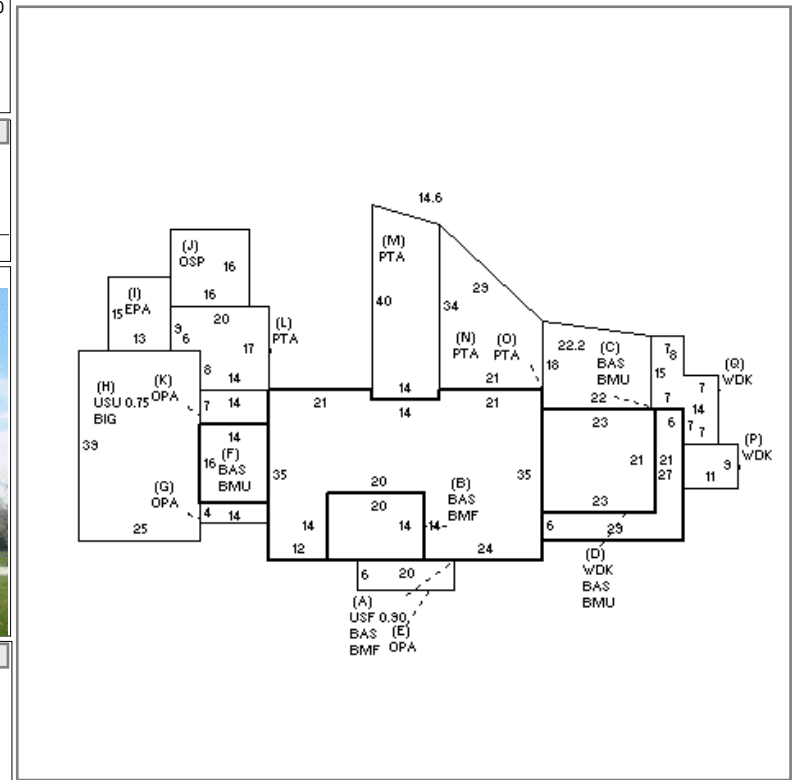

BUILDING

Table with columns: BUILDING, CD, ADJ, DESC, MEASURE, LIST, REVIEW, and building specifications.

Table with columns: BLDG COMMENTS and text describing building features like 'BMF=4 ROOMS/BATH'.

INDING

Large summary table with columns: YEAR BLT, SIZE ADJ, ELEMENT, CD, DESCRIPTION, ADJ, S, BAT, T, DESCRIPTION, UNITS, YB, ADJ PRICE, RCN, and various totals.