

Key: 2054

Town of CHATHAM - Fiscal Year 2024

9/7/2023 9:38 am SEQ #: 2.221

LEG  
AL  
LAND

Table with columns: CURRENT OWNER, PARCEL ID, LOCATION, TRANSFER HISTORY, DOS, T, SALE PRICE, BK-PG (Cert), CREDIT AMT, ADJ VALUE.

Table with columns: CLASS, CLASS%, DESCRIPTION, BN ID, BN, CARD, PMT NO, PMT DT, TY, DESC, AMOUNT, INSP, BY, 1st, %.

Table with columns: TOTAL, ZONING, FRNT, ASSESSED, CURRENT, PREVIOUS.

Table with columns: TY, QUAL, COND, DIM/NOTE, YB, UNITS, ADJ PRICE, RCNLD.

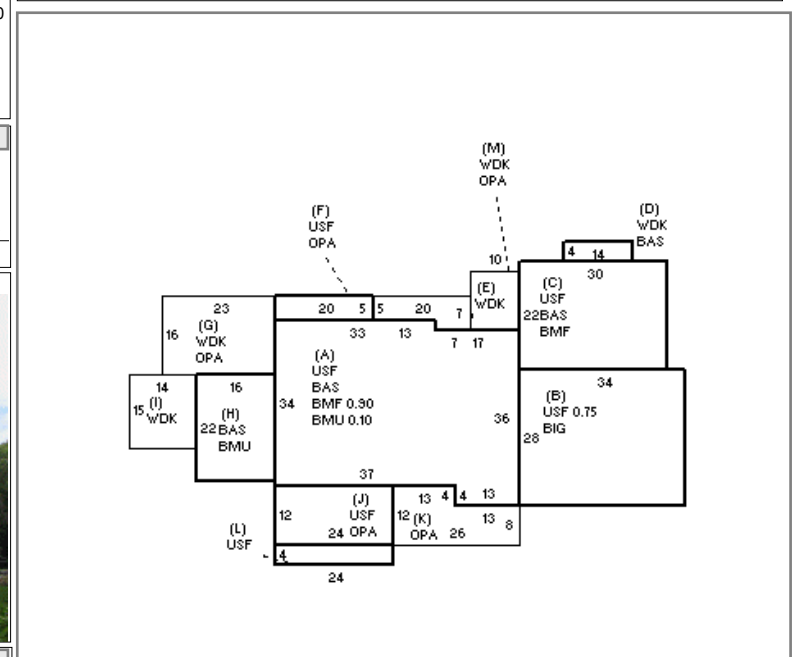

Table with columns: BUILDING, CD, ADJ, DESC, MEASURE, LIST, REVIEW.

BLDG COMMENTS: BMF=LNDRY RM, EXERCISE RM, REC RM, 1 1/2 BATHS, BD RM, 1 OUTDOOR GFP

DET  
ACHED

B  
U  
I  
L  
D  
I  
N  
G

Table with columns: YEAR BLT, SIZE ADJ, ELEMENT, CD, DESCRIPTION, ADJ, S, BAT, T, DESCRIPTION, UNITS, YB, ADJ PRICE, RCN, TOTAL RCN, CONDITION ELEM, CD, EFF. YR/AGE, COND, FUNC, ECON, DEPR, RCNLD.