

Key: 2058

Town of CHATHAM - Fiscal Year 2024

9/7/2023 9:38 am SEQ #: 2.227

LEG
A
L
L
A
N
D

CURRENT OWNER				PARCEL ID				LOCATION				
AVERY JILL J 381 BEACON ST BOSTON, MA 02116				13L-2-C31				34 OLD SALT WORKS RD				
TRANSFER HISTORY				DOS	T	SALE PRICE	BK-PG (Cert)					
AVERY JILL J				08/29/2014	QS	2,415,000	(204315)					
OLD SALT WORKS REALTY TRU				04/04/1995	A	1	(136819)					
LARSEN THOMAS H				11/04/1980	N	1	(83488)					
CD	T	AC/SF/UN	Nbhd	Inf1	Inf2	ADJ BASE	SAF	Inf3	Lpi	VC	CREDIT AMT	ADJ VALUE
100	S	36,820	NC	1.00	100	1.00	100	1.00	OF6	11.00		3,644,550

CLASS	CLASS%	DESCRIPTION			BN ID	BN	CARD	
1010	100	SINGLE FAMILY				1	1 of 1	
PMT NO	PMT DT	TY	DESC	AMOUNT	INSP	BY	1st	%
15-538	09/14/2015	6	Pools etc	75,000			100	100
15-536	09/14/2015	1	New Construc		04/22/2022	NF	100	100
15-049	02/11/2015	3	Renovations	1,100,000	06/12/2017	NF	100	100
15-048	02/04/2015	5	Demolitions	1,100,000	06/12/2017	NF	100	100
	05/12/2008	50	Meas & List			RRC	100	100

TOTAL	36,820 SF	ZONING	R40	FRNT	0	ASSESSED	CURRENT	PREVIOUS
Nbhd	NORTH CHATHAM	NOTE				LAND	3,644,600	3,037,000
Inf1	100		LAND	2,304,200	1,963,600			
Inf2	100		DETACHED	103,400	96,500			
			OTHER	0	0			
		TOTAL	6,052,200	5,097,100				

DE
T
A
C
H
E
D

TY	QUAL	COND	DIM/NOTE	YB	UNITS	ADJ PRICE	RCNLD
PTD	V	1.50	30 0.70	1978	520	16.95	6,200
IPG	V	1.50	10 0.90 16X26	2016	416	65.52	24,500
PLH	V	1.50	10 0.90 17X12	2016	204	386.46	71,000
STR	A	1.00	10 0.90 3X21		63	30.00	1,700

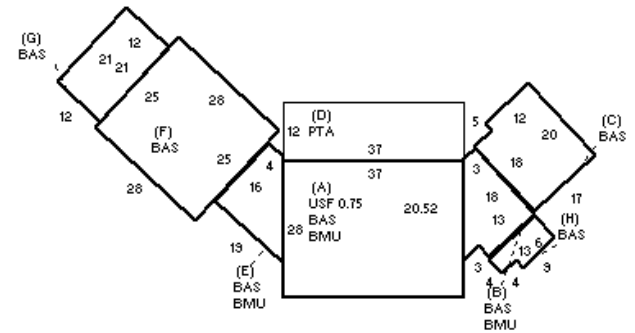

B
U
I
L
D
I
N
G

BUILDING	CD	ADJ	DESC	MEASURE	6/28/2016	WFF
MODEL	1		RESIDENTIAL	LIST	6/28/2016	WFF
STYLE	4	1.00	CAPE [100%]	REVIEW	7/20/2017	TD
QUALITY	V	2.35	VERY GOOD [100%]			
FRAME	1	1.00	WOOD FRAME [100%]			

BLDG COMMENTS

YEAR BLT	1973	SIZE ADJ	1.000	ELEMENT	CD	DESCRIPTION	ADJ	S	BAT	T	DESCRIPTION	UNITS	YB	ADJ PRICE	RCN	TOTAL RCN	2,304,206	
NET AREA	3,538	DETAIL ADJ	1.060	FOUNDATION	4	FLR & WALL	1.00	+	BMU	N	BSMT UNFINISHED	1,409		158.65	223,541	CONDITION ELEM	CD	
\$NLA(RCN)	\$651	OVERALL	1.000	EXT. COVER	1	WOOD SHINGLE	1.00	A	USF	L	UP-STRY FIN	777	1973	477.63	371,121	EXTERIOR	V	
				ROOF SHAPE	1	GABLE	1.00	+	BAS	L	BAS AREA	1,739	1973	562.89	978,874	INTERIOR	V	
				ROOF COVER	2	WOOD SHIN	1.01	D	PTA	N	PATIO/STOOP	444		42.07	18,678	KITCHEN	V	
				FLOOR COVER	1	HARDWOOD	1.00	+	BAS	L	BAS AREA	1,022	2015	562.89	575,278	BATHS	V	
				INT. FINISH	2	DRYWALL	1.00	F11	O	FPL 1S 1OP	1			17,571.00	17,571	BATHS	V	
				HEATING/COOL	11	HT-WT/COOL AIR	1.05	F21	O	FPL 2S 1OP	3			24,383.60	73,151	HEAT	U	
				FUEL SOURCE	1	OIL	1.00	GFP	O	GAS LOG/FP/E FP	1			14,621.70	14,622	ELECT	U	
								ODS	O	OUT DOOR SHWR-A	1			3,471.00	3,471			
																	EFF.YR/AGE	2022 / 0
																	COND	0 0 %
																	FUNC	0
																	ECON	0
																	DEPR	0 % GD 100
																	RCNLD	\$2,304,200