

Key: 2082

Town of CHATHAM - Fiscal Year 2024

9/7/2023 9:38 am SEQ #: 2.252

LEGAL

Table with columns: CURRENT OWNER, PARCEL ID, LOCATION, TRANSFER HISTORY, DOS, T, SALE PRICE, BK-PG (Cert)

Table with columns: CLASS, CLASS%, DESCRIPTION, BN ID, BN, CARD, PMT NO, PMT DT, TY, DESC, AMOUNT, INSP, BY, 1st, %

LAND

Table with columns: CD, T, AC/SF/UN, Nbhd, Inf1, Inf2, ADJ BASE, SAF, Inf3, Lpi, VC, CREDIT AMT, ADJ VALUE

Table with columns: TOTAL, ZONING, R40, FRNT, 0, ASSESSED, CURRENT, PREVIOUS, Nbhd, NORTH CHATHAM, Inf1, 100, Inf2, 100

DETACHED

PHOTO 04/22/2022: Image of a large house with a driveway and lawn.

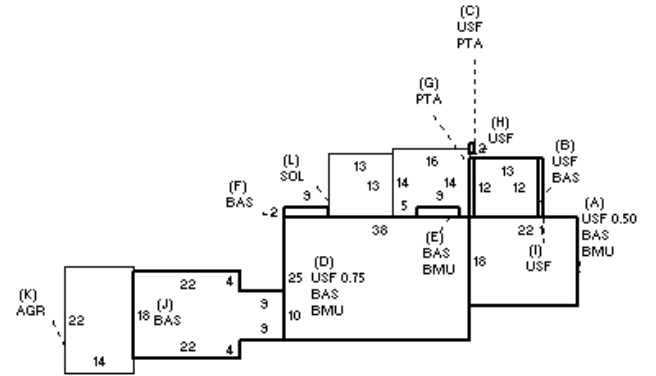

BUILDING

Table with columns: BUILDING, CD, ADJ, DESC, MEASURE, LIST, REVIEW, 5/10/2022, MR

Table with columns: YEAR BLT, SIZE ADJ, 1.000, NET AREA, 3,117, \$NLA(RCN), \$426, ELEMENT, CD, DESCRIPTION, ADJ, S, BAT, T, DESCRIPTION, UNITS, YB, ADJ PRICE, RCN

Table with columns: TOTAL RCN, 1,327,535, CONDITION ELEM, CD, EXTERIOR, INTERIOR, KITCHEN, BATHS, HEAT, ELECT, EFF. YR/AGE, 1992 / 30, COND, 24 24 %, FUNC, 0, ECON, 0, DEPR, 24 % GD, 76, RCNLD, \$1,008,900