

Key: 2143

Town of CHATHAM - Fiscal Year 2024

9/7/2023 9:38 am SEQ #: 2.319

LEG  
AL  
LAND

CURRENT OWNER				PARCEL ID				LOCATION			
OLEARY JASON & CATHERINE 121 STAGE ISLAND RD CHATHAM, MA 02633				14A1-9-D40				121 STAGE ISLAND RD			
TRANSFER HISTORY				DOS	T	SALE PRICE	BK-PG (Cert)				
OLEARY JASON & CATHERINE				04/30/2020	A	1 (222388)					
THE ISLAND TRUST				06/18/2018	A	100 (216469)					
OLEARY JASON & CATHERINE				05/22/2017	QS	2,050,000 (212961)					

CLASS	CLASS%	DESCRIPTION			BN ID	BN	CARD	
1010	100	SINGLE FAMILY				1	1 of 1	
PMT NO	PMT DT	TY	DESC	AMOUNT	INSP	BY	1st	%
19-111	02/26/2019	6	Pools etc	60,000	02/04/2020	TCK	100	100
	07/13/2017	98	SALES QUESTI				0	0
	03/24/2008	50	Meas & List			RRC	100	100
07-558	11/14/2007	2	Additions	350,000	03/24/2008		100	100
95-452	12/01/1996	99	n/a	175,000			100	100

LAND

CD	T	AC/SF/UN	Nbhd	Inf1	Inf2	ADJ BASE	SAF	Inf3	Lpi	VC	CREDIT AMT	ADJ VALUE
100	S	33,504	MOR	1.00	100	1,172,800	1.16	100	1.00	R13	3.20	1,042,320

TOTAL	33,504 SF	ZONING	R40	FRNT	0	ASSESSED	CURRENT	PREVIOUS
Nbhd	MORRIS ISLAND	N O T E	BEACH RIGHTS ON CHATHAM HARBOR, END OF QUITNESSET PATH			LAND	1,042,300	868,600
Inf1	100		BUILDING	2,314,000	1,971,500			
Inf2	100		DETACHED	52,900	50,400			
			OTHER	0	0			
					TOTAL	3,409,200	2,890,500	

DET  
ACHED

TY	QUAL	COND	DIM/NOTE	YB	UNITS	ADJ PRICE	RCNLD	PHOTO
IPC	V	1.50	10 0.90 20X34	2019	680	64.03	39,200	02/04/2020
PTD	V	1.50	10 0.90 IRR	2019	900	16.95	13,700	

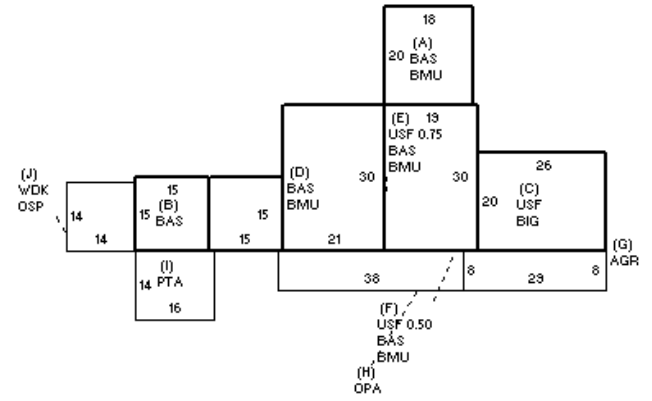

B  
U  
I  
L  
D  
I  
N  
G

BUILDING	CD	ADJ	DESC	MEASURE	LIST	REVIEW	3/4/2020	MR
MODEL	1		RESIDENTIAL					
STYLE	4	1.00	CAPE [100%]					
QUALITY	V	2.35	VERY GOOD [100%]					
FRAME	1	1.00	WOOD FRAME [100%]					

YEAR BLT	1996	SIZE ADJ	1.000	ELEMENT	CD	DESCRIPTION	ADJ
NET AREA	3,288	DETAIL ADJ	1.030	FOUNDATION	4	FLR & WALL	1.00
\$NLA(RCN)	\$704	OVERALL	1.000	EXT. COVER	1	WOOD SHINGLE	1.00
				ROOF SHAPE	1	GABLE	1.00
				ROOF COVER	1	ASPH/CMP SHIN	1.00
				FLOOR COVER	16	HARDWD/OTHER	1.00
				INT. FINISH	2	DRYWALL	1.00
				HEATING/COOL	9	WARM/COOL AIR	1.03
				FUEL SOURCE	2	GAS	1.00

S	BAT	T	DESCRIPTION	UNITS	YB	ADJ PRICE	RCN	TOTAL RCN	2,314,045
+	BMU	N	BSMT UNFINISHED	1,785		152.76	272,685		
+	BAS	L	BAS AREA	2,010	1996	551.24	1,107,985		
C	BIG	N	BUILT-IN GARAGE	520		177.05	92,068		
C	USF	L	UP-STRY FIN	520	2007	467.74	243,225		
+	USF	L	UP-STRY FIN	758	1996	467.74	354,549		
G	AGR	N	ATTACHED GARAGE	232		177.05	41,076		
H	OPA	N	OPEN PORCH	304		178.83	54,365		
I	PTA	N	PATIO/STOOP	224		42.07	9,424		
J	OSP	N	OPEN SCR PORCH	196		185.18	36,296		
J	WDK	N	WOOD DECK	196		137.24	26,898		
F22	O		FPL 2S 2OP	1		34,145.50	34,146		
GFP	O		GAS LOG/FP/E FP	1		14,621.70	14,622		
ODS	O		OUT DOOR SHWR-A	1		3,471.00	3,471		

CONDITION ELEM	CD
EXTERIOR	G
INTERIOR	V
KITCHEN	V
BATHS	V
HEAT	U
ELECT	U

EFF.YR/AGE	2022 / 0
COND	0 0 %
FUNC	0
ECON	0
DEPR	0 % GD 100
RCNLD	\$2,314,000